

Original Instruction Manual

AC400 Two Stage Air Filter with Remote, 3 Speeds & Time Delay

Version 3.1
January 2014



To register this product please visit
www.recordpower.info

It is important to register your product as soon as possible in order to receive efficient after sales support and be entitled to the full **5 year guarantee**. Your statutory rights are not affected. Please see back cover for contact details.



Always wear safety glasses when using woodworking equipment.



Always read the instructions provided before using woodworking equipment.

Important

For your safety read instructions carefully before assembling or using this product.

Save this manual for future reference.

Contents

- 1 Explanation of Symbols
- 2 General Health & Safety Guidance
- 3 Additional Health & Safety Guidance
for Air Filters
- 4 Record Power Guarantee
- 5 Specifications
- 6 Unpacking & Checking Contents
- 7 Assembly
- 8 Operation
- 9 Maintenance
- 10 Electrical Connection & Wiring Diagram
- 11 Parts Lists & Diagrams
EU Certificate of Conformity

1. Explanation of Symbols

THE SYMBOLS AND THEIR MEANINGS SHOWN BELOW MAY BE USED THROUGHOUT THIS MANUAL. PLEASE ENSURE THAT YOU TAKE THE APPROPRIATE ACTION WHEREVER THE WARNINGS ARE USED.

Mandatory Instructions



Read and fully understand the instruction manual before attempting to use the machine.



Indicates an instruction that requires particular attention



Wear protective eyewear



Use respiratory protective equipment



Use hearing protection



Use suitable protective footwear



Use protective work gloves

Warning



Indicates a risk of severe personal injury or damage to the machine



Indicates a risk of severe personal injury from electrical shock



Risk of personal injury from lifting of heavy items



Indicates a risk of severe personal injury from airborne objects



Risk of fire

2. General Health & Safety Guidance

Ensure that you carefully read and fully understand the instructions in this manual before assembly, installation and use of this product. Keep these instructions in a safe place for future reference.

WARNING: for your own safety, do not attempt to operate this machine until it is completely assembled and installed according to these instructions.

WARNING: When using any machine, basic safety precautions should always be followed to reduce the risk of fire, electric shock and personal injury.

Safe Operation

1. Use Personal Protective Equipment (PPE)

- The operation of any machine can result in foreign objects being thrown into your eyes, which can result in severe eye damage. Protective eyewear or other suitable eye protection or face shield should be used at all times. Everyday spectacles only have impact resistant lenses. They are not protective eyewear and do not give additional lateral protection.
- Use respiratory protective equipment (dust mask etc.) if the machining operation creates dust. Exposure to high levels of dust created by machining hardwoods, softwoods and man made composite boards can result in serious health problems. Some imported hardwoods give off highly irritating dust, which can cause a burning sensation. The use of respiratory protective equipment should not be seen as an alternative to controlling the risk of exposure at source by using adequate dust extraction equipment.
- The use of ear plugs or ear defenders is recommended when the machine is in use, particularly if the noise level exceeds 85 dB.
- Wear suitable protective gloves when handling cutting tools or blades. Gloves should NOT be worn when using the machine as they can be caught in moving parts of the machine.
- Non-slip safety footwear is recommended when using the machine and handling large work pieces.

2. Dress appropriately

- Do not wear loose clothing, neckties or jewellery; they can be caught in moving parts of the machine.
- Roll up long sleeves above the elbow.
- Wear protective hair covering to contain long hair.

3. Safety warnings

- Find and read any warning labels on the machine
- It is important that any labels bearing health and

safety warnings are not removed, defaced or covered. Replacement labels can be obtained by contacting our Customer Service Department.

4. Familiarise yourself with the machine

- If you are not thoroughly familiar with the operation of this machine, obtain advice from your supervisor, instructor, or other qualified person or contact your retailer for information on training courses. Do not use this machine until adequate training has been undertaken.

5. Take care when moving or positioning the machine

- Some machines can be very heavy. Ensure the floor of the area in which the machine is to be used is capable of supporting the machine.
- The machine and its various components can be heavy. Always adopt a safe lifting technique and seek assistance when lifting heavy components. In some cases it may be necessary to use mechanical handling equipment to position the machine within the work area.
- Some machines have optional wheel kits available to allow them to be manoeuvred around the workshop as required. Care should be taken to install these according to the instructions provided.
- Due to the nature of the design of some machines the centre of gravity will be high making them unstable when moved. Extreme care should be taken when moving any machine.
- If transportation of the machine is required then all precautions relating to the installation and handling of the machine apply. In addition, ensure that any vehicles or manual handling equipment used for transportation are of adequate specification.

6. The machine should be level and stable at all times

- When using a leg stand or cabinet base that is designed to be fitted to the machine, always ensure that it is securely fastened to the machine using the fixings provided.
- If the machine is suitable to be used on a workbench, ensure that the workbench is well constructed and capable of withstanding the weight of the machine. The machine should always be securely fastened to the workbench with appropriate fixings.
- Where possible, floor standing machines should always be secured to the floor with fixings appropriate to the structure of the floor.

2. General Health & Safety Guidance

- The floor surface should be sound and level. All of the feet of the machine should make contact with the floor surface. If they do not, either re-locate the machine to a more suitable position or use packing shims between the feet and the floor surface to ensure the machine is stable.

7. Remove adjusting keys and wrenches

- Ensure that all adjusting wrenches and keys are removed before switching the machine 'ON'. There is a risk of severe personal injury or damage to the machine from airborne objects.

8. Before switching the machine 'ON'

- Clear the machine table of all objects (tools, scrap pieces etc.)
- Make sure there is no debris between the work piece and the table / work support.
- Ensure that the work piece is not pressed against, or touching the saw blade or cutting tool.
- Check all clamps, work holding devices and fences to ensure that they are secure and cannot move during machining operations.
- Plan the way that you will hold and feed the work piece for the entire machining operation.

9. Whilst machining

- Before starting work, watch the machine while it runs. If it makes an unfamiliar noise or vibrates excessively, switch the machine 'OFF' immediately and disconnect it from the power supply. Do not restart until finding and correcting the source of the problem.

10. Keep the work area clear

- Working clearances can be thought of as the distances between machines and obstacles that allow safe operation of every machine without limitation. Consider existing and anticipated machine needs, size of material to be processed through each machine and space for auxiliary stands and/or work tables. Also consider the relative position of each machine to one another for efficient material handling. Be sure to allow yourself sufficient room to safely operate your machines in any foreseeable operation.
- Cluttered work areas and benches create the risk of accidents. Keep benches clear and tidy away tools that are not in use.
- Ensure that the floor area is kept clean and clear of any dust and debris that may create trip or slip hazards.

11. Consider the work area environment

- Do not expose the machine to rain or damp conditions.
- Keep the work area well lit and ensure that there is

artificial lighting available when there is insufficient natural light to effectively light the work area. Lighting should be bright enough to eliminate shadow and prevent eye strain.

- Do not use the machine in explosive environments eg. in the presence of flammable liquids, gases or dust.
- The presence of high levels of dust created by machining wood can present a risk of fire or explosion. Always use dust extraction equipment to minimise the risk.

12. Keep other persons away (and pets)

- The machine is designed to be used by one person only.
- Do not let persons, especially children, touch the machine or extension cable (if used) and keep visitors away from the work area.
- Never leave the machine running unattended. Turn the power supply off and do not leave the machine unattended until it comes to a complete stop.
- If the work area is to be left unattended, all machinery should be switched 'OFF' and isolated from the mains power supply.

13. Store machines safely when not in use

- When not in use, machines should be stored in a dry place, out of reach of children. Do not allow persons unfamiliar with these instructions or with the machine to operate it.

14. Do not overreach

- Choose a working position that allows your body to remain balanced and feed the work piece in to the machine without overreaching.
- Keep proper footing and balance at all times.

15. Electrical supply

- Electrical circuits should be dedicated to each machine or large enough to handle combined motor amp loads. Power outlets should be located near each machine so that power or extension cables are not obstructing high-traffic areas. Observe local electrical guidelines for proper installation of new lighting, power outlets, or circuits.
- The machine must be connected to an earthed power supply.
- The power supply must be equipped with a circuit breaker that provides short circuit, overload and earth leakage protection.
- The voltage of the machine must correspond to the voltage of the mains power supply.
- The mains plug fitted to the machine should always match the power outlet. Do not modify the plug in any

2. General Health & Safety Guidance

way. If a replacement plug is required it should be fitted by a competent person and of the correct type and rating for the machine.

- If you are unsure about any electrical connections always consult a qualified electrician.

16. Avoid unintentional starting of the machine

- Most machines are fitted with a no-volt release (NVR) switch to prevent unintentional starting. If in doubt always ensure the machine switch is in the 'OFF' position before connecting it to the power supply. This means the machine will not automatically start up after a power cut or switching on of the power supply, unless you first reset the start switch.

17. Outdoor use

- Your machine should not be used outdoors.

18. Extension cables

- Whenever possible, the use of extension cables is not recommended. If the use of an extension cable is unavoidable, then it should have a minimum core cross section of 2.5mm² and limited to a maximum length of 3 metres.
- Extension cables should be routed away from the direct working area to prevent a trip hazard.

19. Guard against electric shock

- Avoid body contact with earthed or grounded surfaces such as pipes and radiators. There is an increased risk of electric shock if your body is earthed or grounded.

20. Always work within the machine's intended capacities

- Operator safety and machine performance are seriously adversely affected if attempts to make the machine perform beyond its limits are made.

21. Do not abuse the power cable

- Never pull the power cable to disconnect it from the power socket. Always use the plug.
- Keep the power cable away from heat, oil and sharp edges.
- Do not use the power cable for carrying or moving the machine.

22. Secure the work piece

- Ensure that the work piece is securely held before starting to machine it.
- When working within 300 mm of the machining area, always use a push stick to feed the work piece in to the blade or cutting tool. The push stick should have a minimum length of 400 mm. If the push stick becomes damaged, replace it immediately.

- Use extra supports (roller support stands etc.) for any work pieces large enough to tip when not held down to the table top.
- Do not use another person as a substitute for a table extension, or as additional support for a work piece that is longer or wider than the basic table, or to help feed, support, or pull the work piece.
- Do not attempt to machine more than one work piece at a time.
- When feeding the work piece towards the blade or cutting tool never position your hands in direct line of the cutting path. Avoid awkward operations and hand positions where a sudden slip could cause your hand or fingers to move into the machining area.

23. Stay alert

- Safety is a combination of operator common sense and alertness at all times when the machine is being used.
- Use all machines with extreme care and do not use the machine when you are tired or under the influence of drugs, alcohol or medication.

24. Use the correct tool for the job

- Do not use the machine for any purpose other than which it was designed.
- When selecting replacement cutting tools and blades, always ensure that they are designed to cut the material that you intend to use them for. If in any doubt seek further advice from the manufacturer.

25. Connect dust extraction equipment

- Always use dust extraction equipment. The dust extractor should be of suitable size and capacity for the machine that it is connected to and have a filtration level appropriate to the type of waste being collected. Refer to the relevant section of the manual for details of the specific dust extraction requirements for this machine.
- The dust extractor should be switched 'ON' before starting the machine that it is connected to. The dust extractor should be left running for 30 seconds after the last machining operation is complete in order to clear any residual waste from the machine.

26. Ensure that the machine is correctly guarded

- Never use the machine if any of the standard safety guards and equipment are removed or damaged.
- Some machines incorporate safety interlocks to prevent the machine from being used without the guards in place. Never attempt to bypass or modify the interlocks to allow the machine to be used without the guards in place.

2. General Health & Safety Guidance

27. Maintain your machine with care

- This manual gives clear instructions on installation, set up and operation of the machine and also details any routine and preventative maintenance that should be performed periodically by the user.
- Remember always to switch off and unplug the machine from the power supply before carrying out any setting up or maintenance operations.
- Follow any instructions for the maintenance of accessories and consumables.
- Do not use compressed air to clean the machine. Always use a brush to dislodge dust in places that are awkward to reach and a dust extractor to collect the waste.
- Inspect electric cables periodically and, if damaged, have them replaced by an authorised service facility or qualified electrician.
- Inspect extension cables (if used) periodically and replace if damaged.

28. Keep cutting tools sharp and clean

- Correctly maintained cutting tools are easier to control and less likely to bind.
- Cutting tools and blades can become hot during use. Take extreme care when handling them and always allow them to cool before changing, adjusting or sharpening them.

29. Disconnect the machine from the power supply

- When not in use, before servicing, changing blades etc. always disconnect the machine from the power supply.

30. Check for damaged parts

- Before each use of the machine, it should be carefully checked to determine that it will operate properly and perform its intended function.
- Check for alignment of moving parts, binding of moving parts, breakage of parts and any other conditions that may affect the operation of the machine.
- A guard or other part that is damaged should be properly repaired or replaced by a qualified person unless otherwise indicated in this instruction manual.
- Do not use the machine if the switch does not turn the machine 'ON' and 'OFF'.
- Have defective switches replaced by a qualified person.

31. Warning!

- The use of any accessory or attachment, other than those recommended in this instruction manual, or recommended by our Company may present a risk of personal injury or damage to the machine and invalidation of the warranty.

32. Have your machine repaired by a qualified person

- This machine complies with the relevant safety rules and standards appropriate to its type when used in accordance with these instructions and with all of the standard safety guards and equipment in place. Only qualified persons using original spare parts should carry out repairs. Failure to do this may result in considerable danger to the user and invalidation of warranty.

33. Caution! Motor may become hot during use

- It is normal for motors on some machines to become hot to the touch during use. Avoid touching the motor directly when in use.

3. Additional Health & Safety Guidance for Air Filters

- Do not use air filtration systems for anything except wood dust. Materials such as liquids, metal shavings, metal dust, screws, glass, plastic or rock can cause sparks and/or damage when coming into contact with any part of the machine.
- Never place hands near the inlet of the machine.
- If ceiling mounted, mounts must be anchored to building structure which will support the weight of the machine. Never mount to surfaces such as dry wall or false ceiling grids, etc.
- Never duct a machine directly into the air filter.
- To avoid a potentially dangerous situation, do not use this equipment to filter volatile fumes or smoke. Air filters are designed and intended for the filtration of airborne wood dust only.

4. Record Power Guarantee

“**Products**” means the Products sold by Record Power subject to these terms and conditions;

“**Record Power**” is Record Power Limited, whose company registration number is 4804158 and registered office address is Centenary House, 11 Midland Way, Barlborough Links, Chesterfield, Derbyshire S43 4XA and sells through a network of Authorised Dealers;

“**Authorised Distributor**” is the nominated importer for your region who will generally sell through a network of Authorised Dealers. Details of Authorised Distributors for specific countries can be found in the Product manual or at www.recordpower.info;

“**Authorised Dealer**” is a retailer or business authorised to sell Record Power Products to end users.

1 Guarantee

- 1.1** Record Power guarantees that for a period of 5 years from the date of purchase the components of qualifying Products (see clauses 1.2.1 to 1.2.9) will be free from defects caused by faulty construction or manufacture.
- 1.2** During this period Record Power, its Authorised Distributor or Authorised Dealer will repair or replace free of charge any parts which are proved to be faulty in accordance with paragraphs 1.1 above provided that:
- 1.2.1** you follow the claims procedure set out in clause 2 below;
- 1.2.2** Record Power, our Authorised Distributor or Authorised Dealer are given a reasonable opportunity after receiving notice of the claim to examine the Product;
- 1.2.3** if asked to do so by Record Power, its Authorised Distributor or Authorised Dealer, you return the Product, at your own cost, to Record Power’s premises or other approved premises such as those of the Authorised Distributor or supplying Authorised Dealer, for the examination to take place;
- 1.2.4** the fault in question is not caused by industrial use, accidental damage, fair wear and tear, wilful damage, neglect, incorrect electrical connection, abnormal working conditions, failure to follow our instructions, misuse, or alteration or repair of the Product without our approval;
- 1.2.5** the Product has been used in a domestic environment only;
- 1.2.6** the fault does not relate to consumable Products such as blades, bearings, drive belts or other wearing parts which can reasonably be expected to wear at different rates depending on usage (for full details contact Record Power or your local Authorised Distributor);
- 1.2.7** the Product has not been used for hire purposes, by you or by a previous owner;

4. Record Power Guarantee

- 1.2.8** the Product has been purchased by you as the guarantee is not transferable from a private sale.
- 1.2.9** where the Product has been purchased from a retailer, the 5 year guarantee is transferable and begins on the date of the first purchase of the Product and in the event of a claim under this guarantee proof of the original purchase date will be required to validate the warranty period.
- 2 Claims Procedure**
- 2.1** In the first instance please contact the Authorised Dealer who supplied the Product to you. In our experience many initial problems with machines that are thought to be due to faulty parts are actually solved by correct setting up or adjustment of the machines. A good Authorised Dealer should be able to resolve the majority of these issues much more quickly than processing a claim under the guarantee.
- 2.2** Any damage to the Product resulting in a potential claim under the guarantee must be reported to the Authorised Dealer from which it was purchased within 48 hours of receipt.
- 2.3** If the Authorised Dealer who supplied the Product to you has been unable to satisfy your query, any claim made under this Guarantee should be made directly to Record Power or its Authorised Distributor (for details of the Authorised Distributor in your country please see your Product manual or check www.recordpower.info for details). The claim itself should be made in a letter setting out the date and place of purchase, and giving a brief explanation of the problem which has led to the claim. This letter should then be sent with proof of the purchase date (preferably a receipt) to Record Power or its Authorised Distributor. If you include a phone number or email address this will help to speed up your claim.
- 2.4** Please note that it is essential that the letter of claim reaches Record Power or its Authorised Distributor on the last day of this Guarantee at the latest. Late claims will not be considered.
- 3 Limitation of Liability**
- 3.1** We only supply Products for domestic and private use. You agree not to use the Product for any commercial, business or re-sale purposes and we have no liability to you for any loss of profit, loss of business, business interruption or loss of business opportunity.
- 3.2** This Guarantee does not confer any rights other than those expressly set out above and does not cover any claims for consequential loss or damage. This Guarantee is offered as an extra benefit and does not affect your statutory rights as a consumer.
- 4 Notice**
This Guarantee applies to all Products purchased from an Authorised Dealer of Record Power within the United Kingdom of Great Britain and Northern Ireland. Terms of Guarantee may vary in other countries – please check with the Authorised Distributor in your country (details of the Authorised Distributor for your country can be found in the manual or at www.recordpower.info).

5. Specifications

Outer Filter:	5 Microns
Inner Filter:	1 Micron
Overall Dimensions:	L514 x W431 x H258 mm
Sound Rating @ 1 m:	High Speed 69 dB Medium Speed 67 dB Low Speed 62 dB
Air Flow:	High Speed 409 CFM Medium Speed 362 CFM Low Speed 260 CFM
Motor:	230V / 50Hz 1/8 hp / 100 W
Full load current:	0.43 A
Timer Settings:	1, 2 and 4 hours
Weight:	14 kg

6. Unpacking & Checking Contents

Contents of Package

- 1 Air Filtration Unit
- 2 Remote Control
- 3 AA Batteries x 2
- 4 Rubber Coated Hook Bolts & Nuts x 4
- 5 Mounting Hook Screws x 4
- 6 Chain sections x 4



7. Assembly

You should take into consideration how and where you will place the unit:

- It can be placed on a bench or be hung from the ceiling.
- This unit will work best if it is located away from corners, and heating/cooling vents.
- If using on sawhorses the air filtration unit should be clamped in place.
- This unit is specifically designed to circulate and filter non-metallic dust, which is generated throughout the work area.



Caution: Mounting hooks must be anchored to a building structure which can support a minimum of 45 kg. Never mount to surfaces such as dry wall or false ceiling grids, etc.

Tools required for assembly:

No 2 Phillips screwdriver (not supplied)

10mm wrench (not supplied)

1. Remove all packing from inside the unit, removing the outer filter and inner filters to gain access. See the maintenance section for details of how to remove the filters.
2. The air filtration unit can be hung from the ceiling. Remove four screws from cabinet top (**Fig 7.1, A**).
3. Hang the unit using four hook bolts (**Fig 7.1, B**), and four hex nuts (**Fig 7.1, C**) provided.
4. The lock nut needs to be threaded almost all the way up the hook bolt. Screw the hook bolt into the hole and tighten lock nut against the cabinet top. You will need to hold the hook bolt so it does not spin while tightening the lock nut.
5. Repeat steps for remaining three hook bolts.
6. Drill holes and securely mount the four mounting hooks provided in the ceiling and use the provided sections of chain for mounting your air filtration system.



Note: Hang the unit at least 2.13M above floor level.

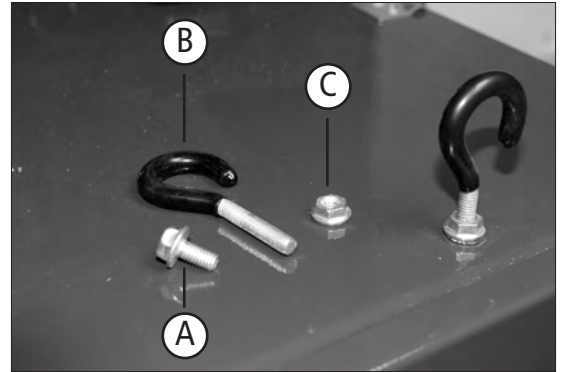

Fig 7.1

8. Operation

Controls & Features

Remote Control

Time button (Fig 8.1) controls the three different timer settings.

1hr will light up on the back of the unit by pressing the time button once. The machine will operate for 1 hour then turn off.

2hr will light up on the back of the unit by pressing the time button twice. The machine will operate for 2 hours then turn off.

4hr will light up on the back of the unit by pressing the time button three times. The machine will operate for 4 hours then turn off.

On/Speed button (Fig 8.1) Turns unit on and controls the three different fan settings, **Hi**, **Mid** and **Low**. There is also an On/Speed button (Fig 8.2) on the switch panel to the rear of the machine which controls the speed and turns the unit ON in **Low** speed.

Off button (Fig 8.1) turns the unit off. There is also a manual off button (Fig 8.2) on the switch panel to the rear of the machine. The fuse is located beneath the rear control panel. If necessary, replace with equivalent 1 A fuse.



Fig 8.1



Warning: To reduce the risk of injury unplug the air cleaner from the power source and ensure the fan is stationary before servicing or changing filters. Failure to comply may cause serious injury.

Restarting

In the Event of a Power Failure

The machine is designed to protect the user against automatic starting of the machine when power is restored after a power failure.

In the event of a power failure, first locate and rectify the source of the failure. If the fault is within the power circuit of the workshop, there may be an underlying cause (circuit overload etc.) that should be investigated by a qualified electrician, before attempting to restore the power source.

Once the power is restored, the machine can be re-started by pressing the 'on' switch.



Fig 8.2

9. Maintenance

Changing the Filters

- There are two filters that need to be periodically cleaned or replaced. The outer filter can easily be removed by disengaging the two clips (**Fig 9.1**).
- Once the outer filter is removed the inner filter can now be pulled out of the unit (**Fig 9.2**). The inner filter can be blown out with air or washed out. The filter should be completely dry before reinstalling into the machine.
- The filters should be replaced and / or cleaned depending on the amount of usage and the environment of your workshop. Clogged filters will reduce the amount of air circulation. The correct way to fit the outer filter is with the wire mesh facing inwards, (**Fig 9.3**).

Replacement Filters

SAC400-26 Inner Pocket Filter – Pos. No. 26

SAC400-27 Electrostatic Outer Filter – Pos. No. 27

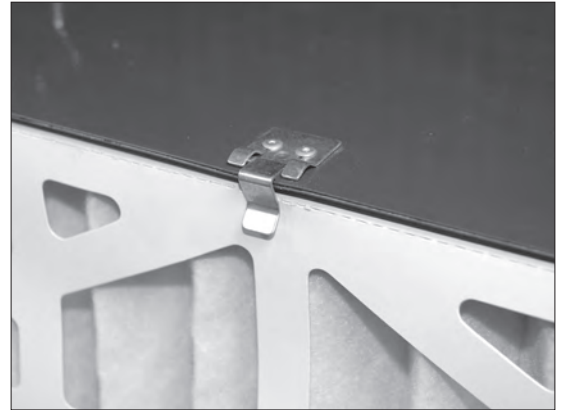

Fig 9.1

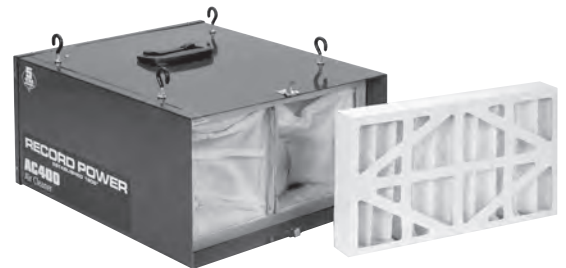

Fig 9.2

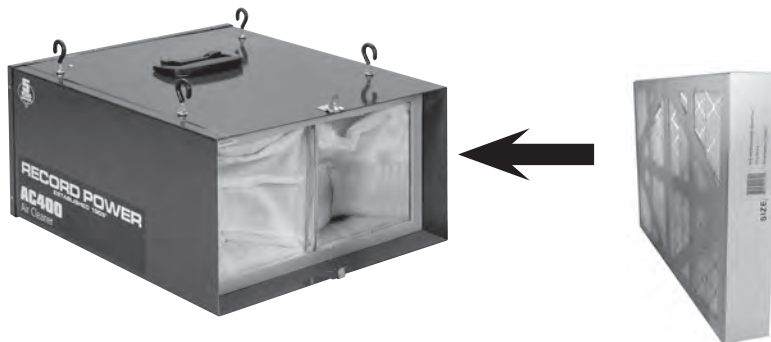

Fig 9.3

10. Electrical Connection & Wiring Diagram

Machines supplied for use in the UK are fitted with a 3 pin plug conforming to BS1363, fitted with a fuse conforming to BS1362 and appropriate to the current rating of the machine.

Machines supplied for use in other countries within the European Union are fitted with a 2 pin Schuko plug conforming to CEE 7/7.

Machines supplied for use in Australia & New Zealand are fitted with a 3 pin plug conforming to AS/NZS3112.

In all cases, if the original plug or connector has to be replaced for any reason, the wires within the mains power cable are colour coded as follows:

230 V (Single Phase)

- Brown: Live (L)
- Blue: Neutral (N)
- Green and Yellow: Earth (E)

The wire coloured brown must always be connected to the terminal marked 'L' or coloured red.

The wire coloured blue must always be connected to the terminal marked 'N' or coloured black.

The wire coloured green and yellow must always be connected to the terminal marked 'E' or with the earth symbol:



or coloured green / green and yellow.

It is important that the machine is effectively earthed. Some machines will be clearly marked with the double insulated logo:



In this case there will not be an earth wire within the circuit.

In the case of the BS1363 plug for use in the UK, always ensure that it is fitted with a fuse conforming to BS1362 appropriate to the rating of the machine. If replacing the original fuse, always fit a fuse of equivalent rating to the original. Never fit a fuse of a higher rating than the original. Never modify the fuse or fuse holder to accept fuses of a different type or size.

Where the current rating of the machine exceeds 13 A at 230 V, or if the machine is designated for use on a 400 V 3 phase supply a connector conforming to BS4343 (CEE17 / IEC60309) will be used.

230 V machines will be fitted with a blue 3 pin connector. The wiring for this type of this connector will be the same as shown above.

400 V, 3 phase machines will be fitted with a red 4 or 5 pin connector. The wiring for this type of connector is as shown below:

400 V (3 phase)

- Brown: Live (L1)
- Black: Live (L2)
- Grey: Live (L 3)
- Blue: Neutral (N)
- Green and Yellow: Earth (E)

The wire coloured brown must always be connected to the terminal marked 'L1'.

The wire coloured black must always be fitted to the terminal marked 'L2'.

The wire coloured grey must always be connected to the terminal marked 'L3'.

The wire coloured blue must always be connected to the terminal marked 'N' or coloured black.

The wire coloured green and yellow must always be connected to the terminal marked 'E' or with the earth symbol. If in doubt about the connection of the electrical supply, always consult a qualified electrician.

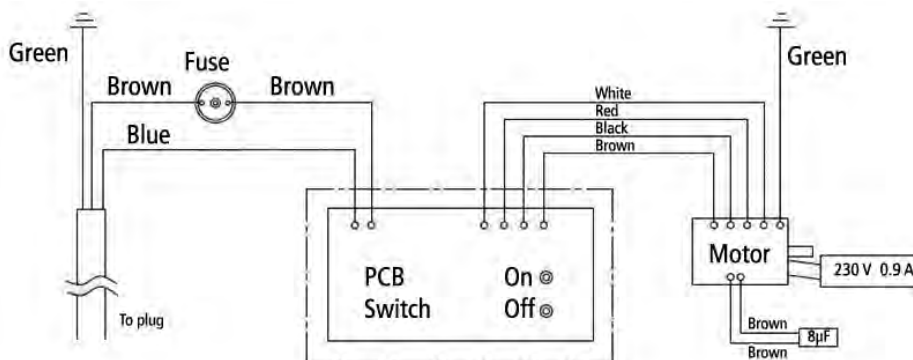

11. Parts Lists & Diagrams

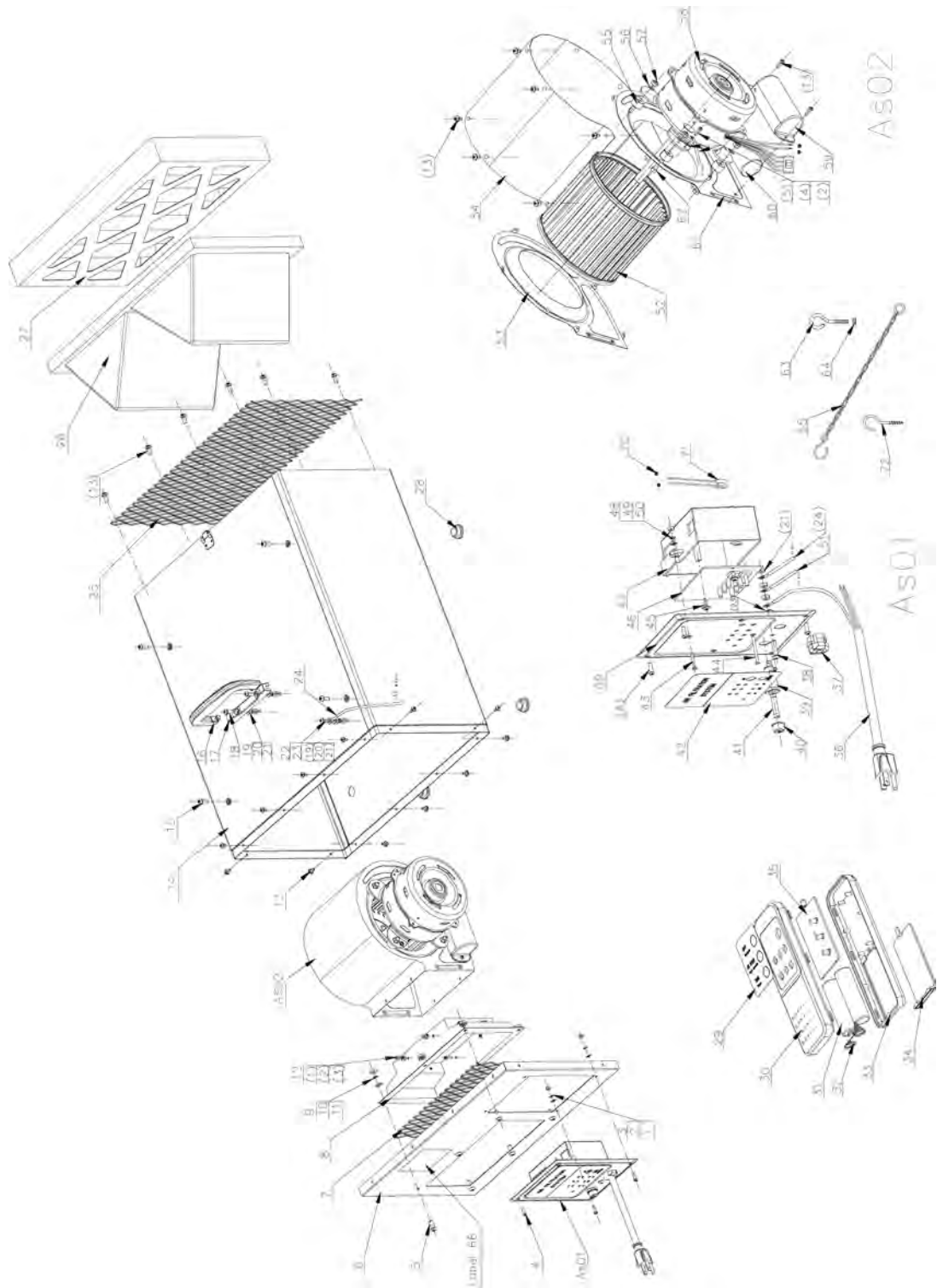

11. Parts Lists & Diagrams

No.	Part Name	Quantity
1	Hex Nut M4	13
2	Flat Washer M4	13
3	Lock Washer M4	13
4	Pan Head Screw M4x12	5
5	Pan Head Screw M6x16	6
6	Air Box Front Cover	1
7	Grille	1
8	Air Duct	1
9	Hex Nut M6	6
10	Flat Washer M6	6
11	Lock Washer M6	6
12	Socket Head Cap Screw M4x12	8
13	Self Tapping Screw ST4x10	34
14	Air box	1
15	Pan Head Screw M6x1	4
16	Handle	1
17	Handle Bracket	1
18	Pan Head Screw M5x16	2
19	Flat Washer M5	3
20	Lock Washer M5	3
21	Hex Nut M5	6
22	Pan Head Screw M5x12	1
23	External Tooth Lock Washer M5	2
24	Earth Wire	1
25	Grille	2
26	Inner Pocket Filter	1
27	Electrostatic Outer Filter	1
28	Rubber Foot	4
29	Remote Control Label	1
30	Remote Control Top Cover	1
31	Battery AA	2
32	Spring	1
33	Remote Control Bottom Cover	1
34	Battery Cover	1
35	Remote Control PCB	1
36	Power Cord	1
37	Strain Relief	1
38	Pan Head Screw M5x20	1
39	Fuse Holder	1
40	Fuse Holder Cap	1
41	Fuse	1

No.	Part Name	Quantity
42	Control Panel Label	1
43	Flat Head Screw M3x15	1
44	Main Wire	1
45	Self Tapping Screw ST3.2x8	1
46	Printed Circuit Board	1
47	Switch Box	1
48	Flat Washer M3	2
49	Lock Washer M3	2
50	Hex Nut M3	2
51	Flat Head Screw M3x30	1
52	Fan Wheel	1
53	Fan Housing Cover	1
54	Fan Housing	1
55	Rubber Spacer	4
56	Large Washer Ø5	4
57	Nylon Insert Lock Nut M5	4
58	Motor	1
59	Capacitor Cover	1
60	Capacitor	1
61	Fan Housing Cover	1
62	Hook Screw	4
63	Hook Bolt	4
64	Flange Nut M6	4
65	Hook Chain	4
66	I.D. Label	1
69	Switch Box Cover	1
70	Lock Wiring Nut	4
71	Wire Strip	1
72	Mounting Hook Screw M5 x 25 mm	4
<hr/>		
AS01	Switch Box Assembly	
AS02	Motor + Fan Assembly	

EU Declaration of Conformity

Cert No: EU / AC400 / 1

Record Power Ltd

Centenary House, 11 Midland Way,
Barlborough Links, Chesterfield, Derbyshire S43 4XA
declares that the machinery described:-

1. Type: **Air Cleaner**
2. Model No: **AC400**
3. Serial No

Conforms with the following directives:-

- Machinery Directive: 2006/42/EC
EN61029-1:2009+A11:2010
- Low Voltage Directive: 2006/95/EC
- Electromagnetic Compatibility: 2004/108/E
EN55014-1:2006+A1:2009
EN55014-2:1997+A1:2001+A2:2008
EN61000-3-2:2006+A1:2009+A2:2009
EN61000-3-3:2008



Signed Dated: 01/01/2014

Andrew Greensted
Managing Director



RECORD POWER

ESTABLISHED 1909®

Woodworking Machinery & Accessories

United Kingdom

Record Power Ltd

Centenary House, 11 Midland Way
Barlborough Links, Chesterfield
Derbyshire S43 4XA

Tel: 01246 571 020

Fax: 01246 571 030

www.recordpower.co.uk

Eire

Record Power Ltd

Centenary House, 11 Midland Way
Barlborough Links, Chesterfield
Derbyshire S43 4XA

Tel: 01246 571 020

Fax: 01246 571 030

www.recordpower.co.uk

Australia

Tools 4 Industry

Po Box 3844
Parramatta 2124

Tel: 1300 124 422

Fax: 1800 262 725

www.recordpower.com.au

New Zealand

Tools 4 Industry

Po Box 276079
Manukau City 2241

Tel: 0800 142 326

Fax: 09 2717 237

www.recordpower.co.nz