

DC



MJ Deflector/Connector (Model # GRDC-020) for the GRR-Ripper® System

**The MJ Handle Bridge Set is required for installation!*

Installation Manual (V1.0) 0705

Micro Jig, Inc.

PO Box 195607
Winter Springs, FL 32719 USA

Tel: 407-696-6695
Web site: www.microjig.com
Email: sales@microjig.com

The MJ Deflector/Connector (D/C) is designed to enhance the user experience of the GRR-Ripper® System. The D/C can be used for chip/dust deflection. It can also serve as a connecting bridge between two GRR-Rippers®, where it allows for multiple configurations when used on the table saw, router table, and shaper. When the D/C is installed behind a GRR-Ripper®, it also serves as a blade cover when exiting the cut on the table saw. The MJ Handle Bridge Set (Model # GRHB-010) must be installed on your GRR-Ripper® (Model # GR-100 or GR-200) prior to installing the MJ D/C. Please refer to the table below for available models.

Copyright © 2005 Micro Jig, Inc.

Made in USA

Model	Contents	Remarks
GRHB-010 MJ Handle Bridge Set Only	Includes only the MJ Handle Bridge Set without the MJ Deflector/Connector	To markedly improve the distribution of pressure on an existing GRR-Ripper®.
GRDC-020 MJ Deflector/Connector Only	Includes only the MJ Deflector/Connector without the MJ Handle Bridge Set	To enhance an existing GRR-Ripper® System previously equipped with the MJ Handle Bridge Set.
GRDB-030 (GRHB-010 + GRDC-020)	Includes both the MJ Handle Bridge Set and the MJ Deflector/Connector	To enhance an existing GRR-Ripper® System with the added features from both accessories.

Handy Built-in Magnifier.
Inspect saw blade tips and other cutting tools.

Package Contents (Model GRDC-020)

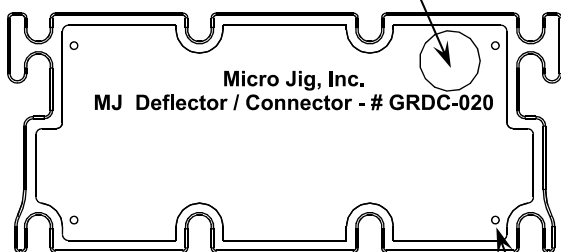

(20) Deflector / Connector - 1 pc
Part # GR-P20

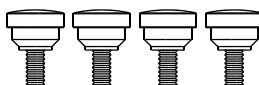

(T) 1/4-20 x 1/2" Thumb Screws - 4 pcs.
Part # GR-H36



(P) Nylon Shoulder Washers - 4 pcs
Part # GR-H14



(S) 5/16" OD Black O-Ring - 4 pcs
Part # GR-H34

Four raised tabs on the top surface of the D/C guard against scratches when placed directly on a flat work surface.

IMPORTANT SAFETY WARNING — READ BEFORE USE

- When using the MJ Deflector/Connector (D/C) behind a GRR-Ripper®, it is recommended that the user follow conventional good judgement and adjust the saw blade so the bottom of the gullet is at or just below the work surface.
- When using the D/C behind a GRR-Ripper®, it is important to prevent the D/C from coming into contact with the spinning saw blade:
 - Do not use the GRR-Ripper® with D/C to feed stock with a tapered top surface, including the MJ Taper Jig.
 - Do not lift off the GRR-Ripper® with D/C at an excessive angle, especially during a leap-frogging operation.

1

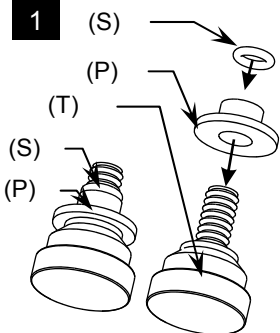

Installation

Step 1:
Slide a Nylon Shoulder Washer (P) onto the thread body of a 1/4-20 x 1/2" Thumb Screw (T) until it rests on the underside of the knob. Then push a 5/16" OD Black O-Ring (S) onto the thread body of the screw until it comes in contact with the Nylon Shoulder Washer (P) as the shown on the left hand side of the drawing. Repeat this step on all four thumb screws.

2

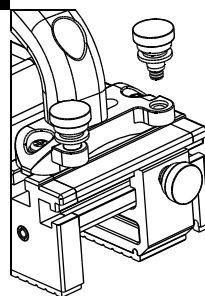

Step 2:

Install the MJ Handle Bridges in the center location of the GRR-Ripper®. Thread the four thumb screw assemblies from Step 1 into the four brass inserts on the Handle Bridge. Tighten all four thumb screw assemblies until all O-Rings are loosely seated into the recesses above the brass inserts.

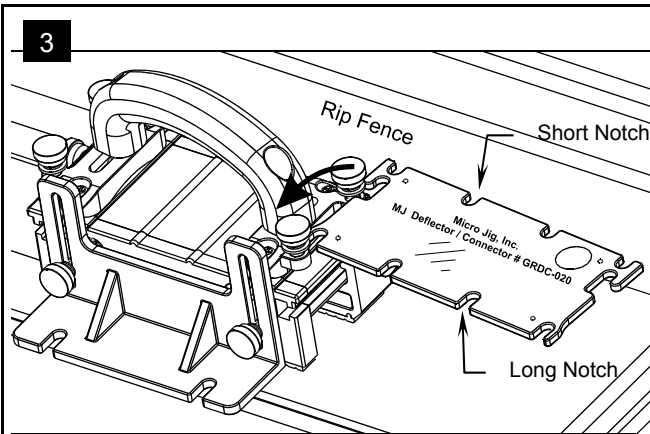

Step 3: Position the Deflector/Connector (D/C) as shown in Drawing 3 with the flat smooth surface facing up. Slide the D/C from the right side of the GRR-Ripper® with the two notches engaged onto the nylon shoulder washers (P). Push the D/C until the Nylon Shoulder Washers (P) are fully seated in the notches. Finger tighten the thumb screws (T). The D/C is now ready for ripping on the table saw (see Drawing 4). When used as a Deflector only (Drawings 4 & 9), the D/C can be easily snapped on or off with firm finger pressure by backing off the thumb screws 1/8 of a turn. The flexible O-Rings will keep the screws in that position without the D/C attached. Do not back off the thumb screws more than necessary or the D/C will disengage with light pressure. The D/C is designed to come off only towards the right (fence) side so it does not come off accidentally in a straight backward direction. Make sure all notches are completely seated in the nylon washers. Use the long notches for snapping in; tighten all thumb screws when using the short notches. Slight adjustments of the handle location may be required in order for the D/C to be properly positioned.

The following drawings illustrate how the MJ Deflector/Connector (D/C) can be configured in different setups. When the D/C is used in the connector mode, all screws for tightening the D/C must be securely fastened!

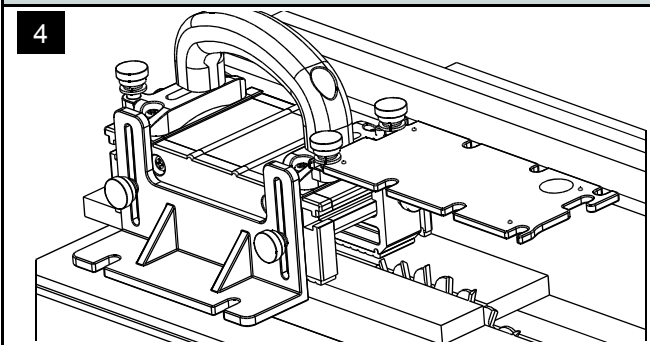

↑ One D/C is used as a chip deflector and blade cover on a single GRR-Ripper® operation on table saw. This setup can also be used with the leap-frogging technique, but do not lift off the GRR-Ripper® with the D/C attached in this position at an excessive angle.

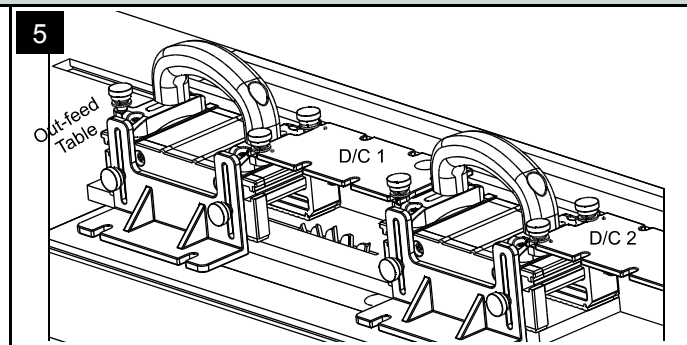

↑ One D/C connects two GRR-Rippers® fore and aft, while a second D/C serves as a deflector. An out-feed table is necessary with this configuration! Use of the MJ Splitter is recommended with this setup.

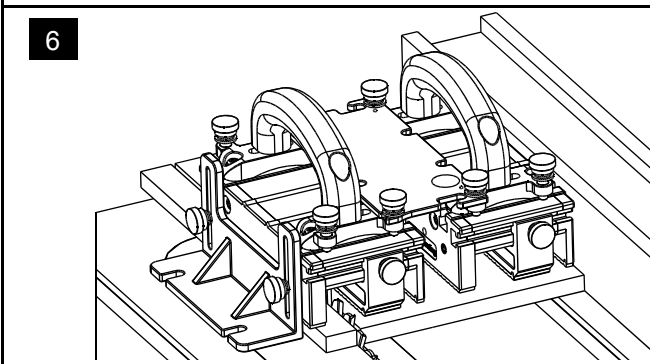

↑ One D/C connects two GRR-Rippers® for wider cuts.

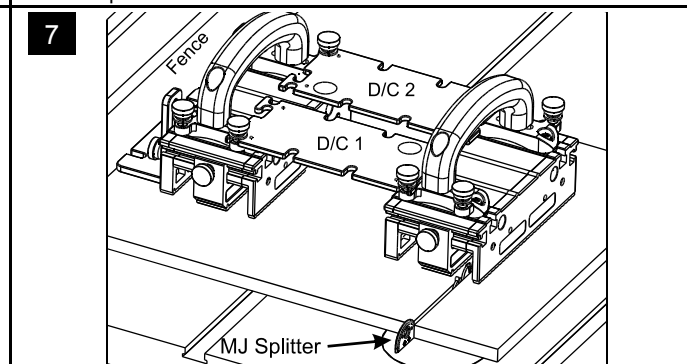

↑ Cut as wide as 13-3/4" with saw blade through tunnel.

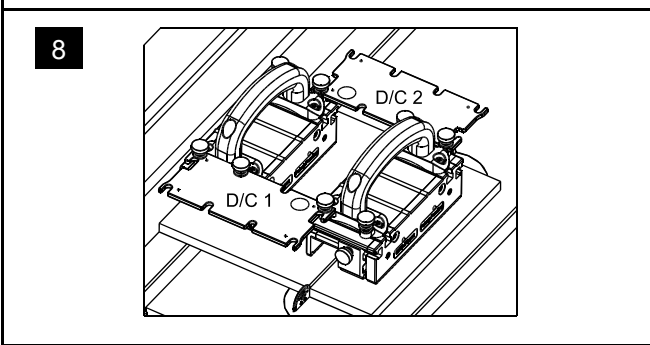

↑ Another way to connect two GRR-Rippers® with a different width than those shown in Drawings 6 & 7.

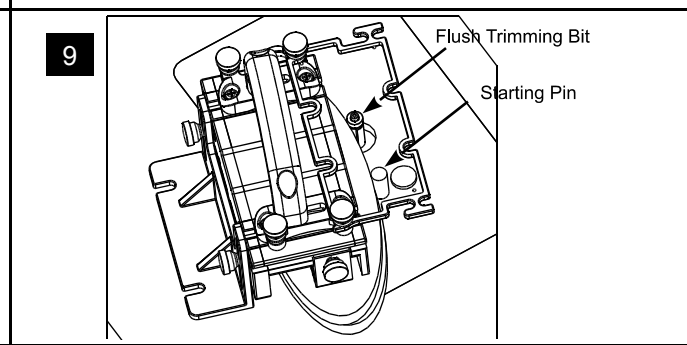

↑ One D/C used as a chip deflector when pattern routing.