

veritas[®]
Shooting Plane



The Veritas® Shooting Plane is designed specifically to be used with a user-made shooting board to accurately trim and square the ends of workpieces. The plane weighs 7¾ lb so that it will have the momentum to easily cut through end grain. The body is just under 16" long and the base surface is 2⅛" wide. This plane is compatible with the Stanley #52 chute board.

The plane features an adjustable mouth that can be closed to a narrow slit for fine shavings with minimum tear-out or opened for heavier cuts. All of this can be done quickly and accurately with the toe locking knob and the unique mouth adjustment screw.

Made of fully stress-relieved, ductile cast iron, the shooting plane is accurately machined and ground so that the sole is flat and the side is square to the sole.

The tote is mounted at an ergonomic angle; however, it can be tilted so that the plane can be used for jointing, as well as other more conventional planing activities.

With its combined feed and lateral adjustment knob, the Norris-style adjustment mechanism makes blade setting easy and accurate. The blade is held in alignment using three set screws, which prevent any sideways movement if a knot is hit.

The 2¼" wide blade has a 25° bevel angle and is mounted at a skewed angle to give a lower effective cutting angle, as well as to drive the workpiece into the reference surfaces of the shooting board. The blade is available in your choice of O1 (Rc58-60) and PM-V11™ (Rc60-63), both of which are easily sharpened with conventional abrasives. (All Veritas 2¼" bevel-up blades will fit this plane.)

The two 10-32 UNF threaded holes in the base can accommodate the fence from the Veritas® Skew Rabbet Plane or the Veritas® Jack Rabbet Plane.

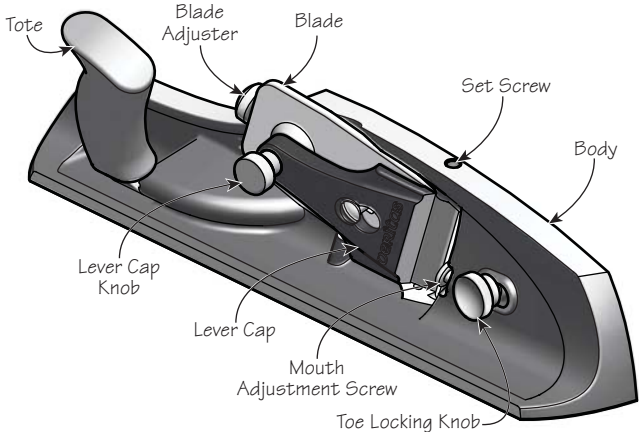

Figure 1: Veritas Shooting Plane.

Installing and Setting the Blade



Caution: Be aware that the blade is sharp; careless handling can result in serious injury.

Position the blade (bevel up) on the blade bed such that the adjuster pin is in the first adjuster hole (see **Figure 2**).

Install the lever cap and lightly tighten the lever cap knob.

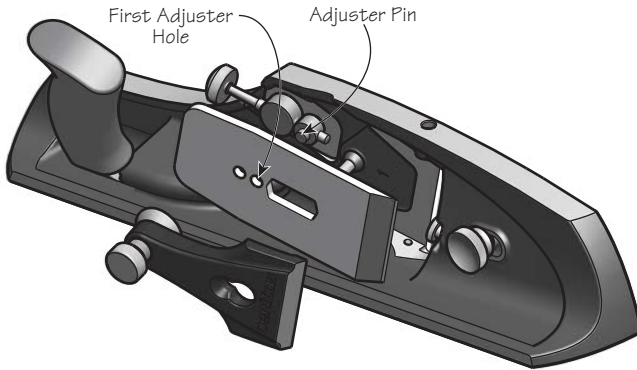

Figure 2: Installing the blade.

To initially set the blade, open the mouth fully, and place the plane on a flat wood surface (e.g., a scrap of stock). Lightly clamp the blade with the lever cap knob and advance the blade until it just touches the wood.

Flip the plane to a sole-up position, then sight along the sole to ensure the blade edge is parallel to the sole and advance or retract it as required. Clamp fully (a quarter turn should be ample – **do not overclamp**) and take a test cut. If all is well, advance the set screws on either side of the body until they just touch the blade, not to clamp it but to create a guide so that you do not have to be concerned about the blade shifting. You will quickly get accustomed to setting blade depth only by sighting along the sole, but for setting very fine shavings, you will still need to take test cuts.

Two Cautionary Notes

1. The lever cap clamping knob has tremendous mechanical advantage. For normal use, it needs to be tightened only a quarter turn after full engagement with the blade. **Never torque it down as hard as you can or you may damage the plane.**
2. Before advancing the blade at any time, check the mouth opening to be sure you don't run the blade against the adjustable toe piece. It is a simple matter to close the mouth to the desired opening **after** you have reached the right blade projection.

Backlash and How to Avoid It

To eliminate the possibility of the blade shifting backward unpredictably as the backlash is taken up, the final setting should always be made with the blade being advanced by the clockwise movement of the blade adjuster. If you need to retract the blade slightly, retract it more than required, and finish by **advancing** it to its desired position. This takes up all the play in the forward direction, resisting the backward forces experienced by the blade.

Mouth Adjustment

The movable toe piece enables you to set the gap between the blade and the toe piece (this opening is called the mouth) to suit the task. Generally, you will want a mouth as small as will allow the shaving to escape. The reason for this is that a tight mouth supports the wood ahead of the blade, preventing break-out, a shaving propagating below the surface of the workpiece.

The mouth adjustment screw allows you to accurately set this opening and, once set, ensures that you cannot inadvertently slide the toe backwards so that it contacts, and possibly damages, the blade. Loosen the toe locking knob and, holding the plane vertically, nose up, adjust the position of the toe by turning the mouth adjustment screw in or out as required. When the desired mouth opening is achieved, tighten the toe locking knob firmly, but avoid overtightening.

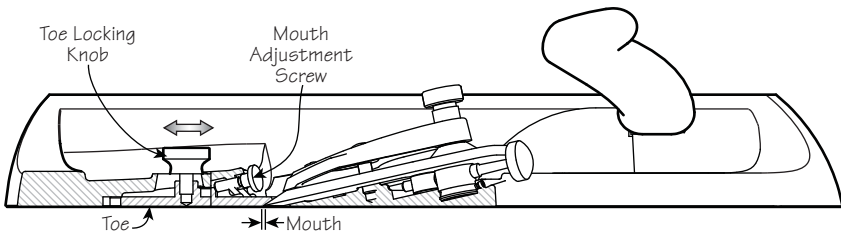

Figure 3: Mouth adjustment.

Tote Adjustment

The shooting plane has a tilting rear tote to allow the plane to be used with the blade down (as shown in **Figure 7**) for more conventional planing activities (e.g., jointing). To adjust the handle, loosen the handle locking screw until the handle is free to rotate on the mounting boss. Tilt the handle to the side so it engages in the required slot in the boss. Tighten the handle locking screw.

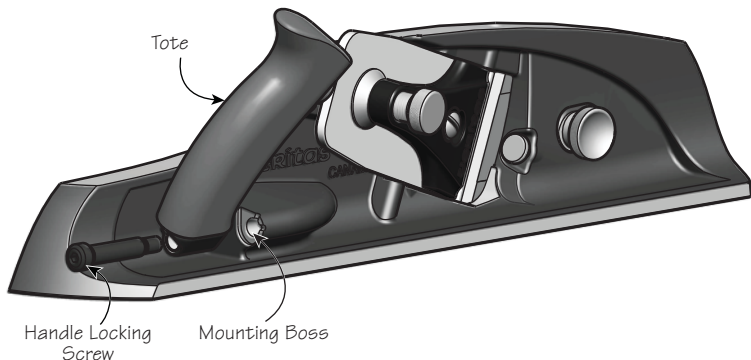

Figure 4: Tote adjustment.

Blade Sharpening

The shooting plane comes with a blade ground to 23° with a 25° micro-bevel. The back of the blade is lapped flat to $0.0005''$ over the working surface.

The 25° bevel blade will be a good starting bevel for end grain in most softwoods and some hardwoods. Ring-porous hardwoods such as oak may require a 30° bevel to prevent blade edge failure. Simply hone the micro-bevel to the required angle.

It is difficult to be definitive about bevel angles. If you are always working clear pine, you can get away with lower bevel angles. Only you know which wood you will be working and how you will be working it. Experience will tell you what you can and cannot do.

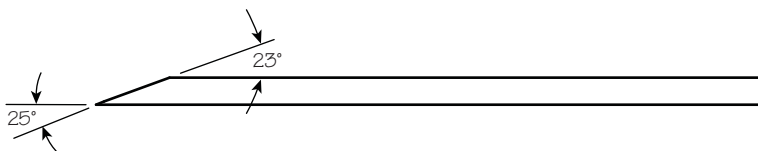

Figure 5: Blade edge geometry, as supplied.

Shooting

The shooting plane is optimized for shooting end grain to achieve accurate end geometry on workpieces. A shooting board is required to accurately guide the plane to cut a perfectly square edge (or a bevelled edge if you want), and holds the workpiece in such a way as to prevent splintering of the end-grain fibers.

The plane has been designed to fit the Stanley #52 chute board that was produced between 1905 and 1943.

There are a number of commercially available shooting boards, as well as several plans available from a number of references.

A user-made shooting board can be as simple or complex as your needs. (See **Figure 6.**) The most critical element is to be sure the fence is accurately placed relative to the reference surface for the plane.

While not entirely critical, incorporating an enclosed track on the board to positively locate the plane will lead to more accurate and repeatable results.

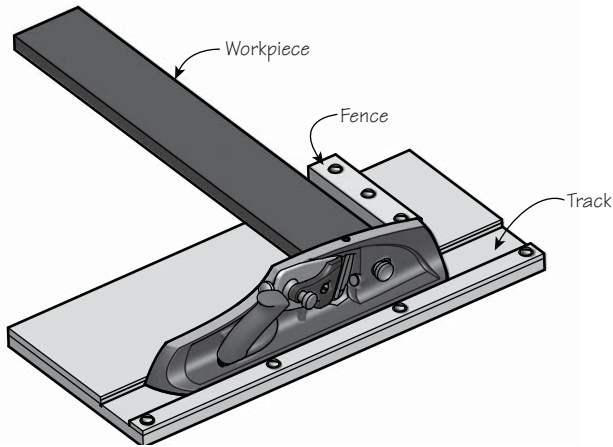

Figure 6: Typical user-made shooting board.

Jointing

Because the tote on the shooting plane can be tilted, the plane can be used for conventional planing activities, such as jointing an edge.

For jointing, it may be helpful to create a jointing board, which is similar to a shooting board but much longer.

Make your jointing board with a perfectly straight reference edge and square reference surface.

Clamp your workpiece to the jointing board with edge to be jointed aligned with the reference edge. Hold the plane such that the base surface is tight against the reference surface.

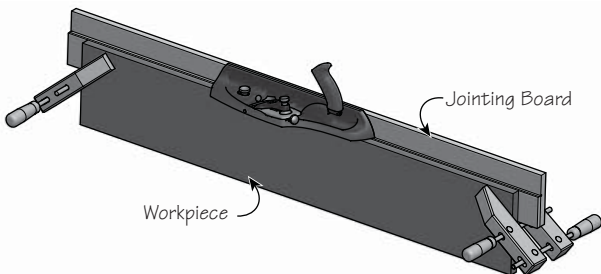

Figure 7: Jointing board.

Care and Maintenance

The body of the shooting plane is ductile cast iron and comes treated with rust preventative. Remove this using a rag dampened with mineral spirits. Clean all machined surfaces, including the area under the nose and the toe itself.

We recommend that you initially, then periodically, apply a light coat of silicone-free paste wax to seal out moisture and prevent rusting (as well as act as a lubricant for smoother planing). Wipe off any wood dust from the surfaces that you will be waxing, apply a light wax coating, let dry, then buff with a clean soft cloth. At the same time, the solvents in the wax will remove any harmful oils left from your fingers that can lead to corrosion.

Before treating a plane with a sealant, wipe off any fingerprints with a cloth dampened with a small amount of light machine oil. Remove any residual oil; then apply the sealant to the plane's sole and cheeks.

If storage conditions are damp or humid, the plane should, in addition to the treatment outlined above, be wrapped in a cloth or stored in a plane sack. This precaution will also guard against dings and scratches.

Every so often, take the plane apart to clean and lubricate it where necessary. Remove the lever cap, blade, adjustment mechanism and toe from the body. Clean all parts with a cloth dampened with a dab of light machine oil. The blade bed and machined contact surfaces between the body and toe, as well as the adjustment components (pivot, threaded shaft and traveller), will benefit from a light coat of oil to keep them working freely. For corroded plane bodies, we recommend you first remove the rust with a fine rust eraser, then treat as described above.

The bright finish on the brass components can be maintained as above. If a patina finish is preferred, simply leave the brass components unprotected until the desired level of oxidation has occurred, then apply a sealant. If you want to make them bright and shiny again, you can revitalize the surface with a brass polish.

The rosewood knob and handle have a lacquer finish and should require nothing more than a wipe with a clean cloth from time to time.

Accessories

- 05P34.02** A2 Blade, 25°
- 05P34.52** O1 Blade, 25°
- 05P34.72** PM-V11™ Blade, 25°
- 05P34.03** A2 Blade, 38°
- 05P34.53** O1 Blade, 38°
- 05P34.73** PM-V11™ Blade, 38°
- 05P34.04** A2 Blade, 50°
- 05P34.54** O1 Blade, 50°
- 05P34.74** PM-V11™ Blade, 50°
- 05P34.06** A2 Blade, Toothed

veritas® Tools Inc.

814 Proctor Avenue 1090 Morrison Drive
Ogdensburg NY 13669-2205 Ottawa ON K2H 1C2
United States Canada

customerservice@veritastools.com

www.veritastools.com