

BENCHCRAFTED

| MOXON VISE

| COMPLETE MOXON VISE

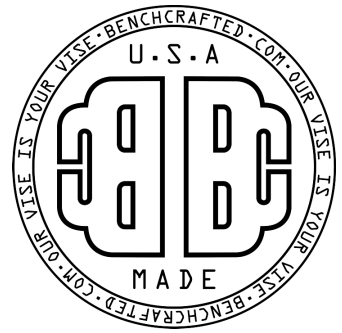

Assembly and Installation Instructions

Version Jan. 2022

Package Contents: Moxon Vise

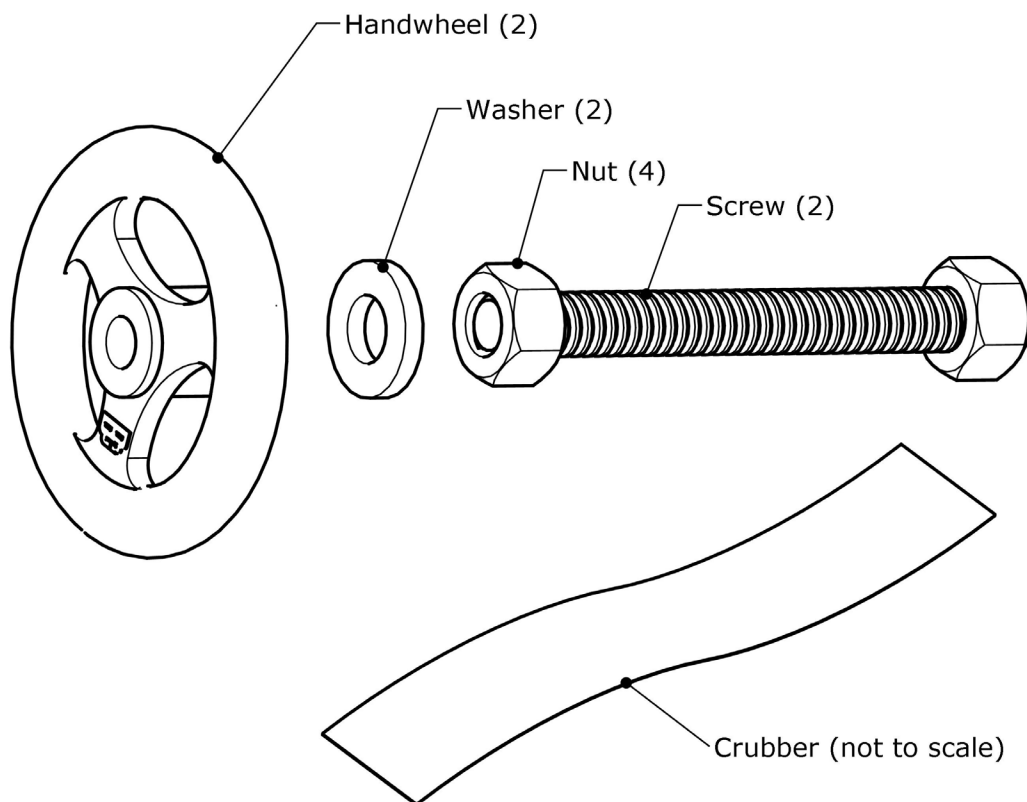

Package Contents: Complete Moxon Vice

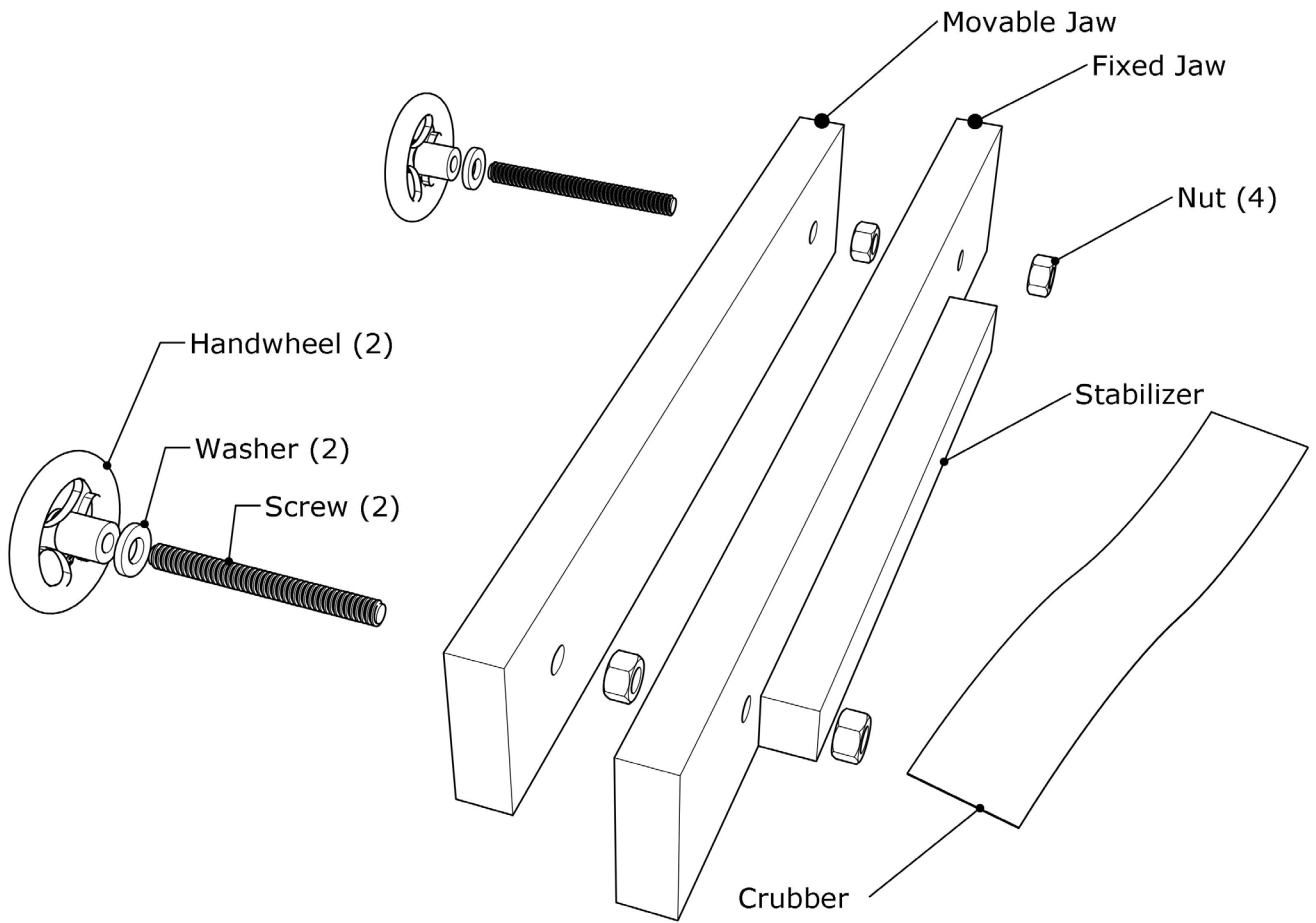

IMPORTANT NOTE ABOUT CRUBBER

Effective September 2021

Due to material shortages beyond our control we may substitute suede leather for Crubber depending on availability. Your vise may come with suede leather instead of Crubber.

If you received suede with your vise, it can be installed in exactly the same way as the Crubber, using the same glues. Any mention of Crubber in these instructions applies directly to suede, whether it be in installation method or function.

Suede performs equally to Crubber.

UNPACKING THE PARTS

The handwheels are heavy. Be careful as you unpack and handle them. Some components have a rust preventative oil applied. You may want to remove this oil before installing the vise. Wipe it off with a paper towel. This will leave a light film of oil on the parts that will help prevent rust and keep the parts moving smoothly.

BUILDING THE VISE

(SKIP AHEAD IF YOU'VE PURCHASED A COMPLETE MOXON VISE)

Mill all the components to 1 3/4" thick. On our complete vises we cut a rectangular mortise for the nut in the fixed chop, but you can also drill a hole to house the nut and pare the six sides to create a hexagonal mortise.

The moveable jaw is 1/8" taller than the fixed jaw (positioned at the bottom) to allow you to easily slide the closed vise up to the edge of your bench, thus lining up the front of the fixed jaw with the front edge of the bench. If your bench front edge isn't in the greatest condition you may want to reduce the height of the fixed jaw for better registration when mounting the vise.

The stabilizer is glued on and then planed flush to the bottom of the fixed jaw. Make sure the bottom is square to the front of the fixed jaw.

The elongated holes (slots) on the movable jaw allow the jaw to skew left to right to hold slightly tapered work. Drill the elongated holes in the moveable jaw with a 3/4" Forstner bit, then shift the jaw over to elongate the hole, finishing up with a couple passes between the two to remove the web. Forstner bits can easily cut partial arcs, just make sure the jaw is clamped securely in your drill press. If you don't have a drill press you can elongate the hole with a round rasp. Make sure the mortise is no greater than 3/4" tall. You want the jaw to pivot horizontally, but have little vertical play.

To assemble the vise, thread a nut onto each screw so 1 3/4" of screw extends past the nut. Insert this end into the nut mortise on the fixed jaw. Now thread a nut onto the screw behind the fixed jaw and cinch it down with a wrench. Install the moveable jaw onto the screws, slip a washer onto

each screw, then spin the handwheels on. A little lubrication used sparingly will keep the wheels running smoothly. A drying-type bicycle chain lubricant is a good choice. Now plane the top edge of the jaws flush with the vise closed. Remove the movable jaw and glue the Crubber to the inside face of the moveable jaw with contact cement or wood glue, then trim it flush to the edges and holes. Ease the edges of the components with a block plane and sandpaper.

COMPLETE MOXON VISE ASSEMBLY

Glue the Crubber to the inside of the moveable jaw with contact cement or wood glue, then trim it flush to the edges and holes.

Thread a nut onto each screw so 1 3/4" of screw extends past the nut. Insert this end into the nut mortise on the fixed jaw. Now thread a nut onto the screw behind the fixed jaw and cinch it down with a wrench. Install the moveable jaw onto the screws, slip a washer onto each screw, then spin the handwheels on. A little lubrication used sparingly will keep the wheels running smoothly. A drying-type bicycle chain lubricant is a good choice.

BIG CHAMFER FOR HALF BLIND DOVETAILS

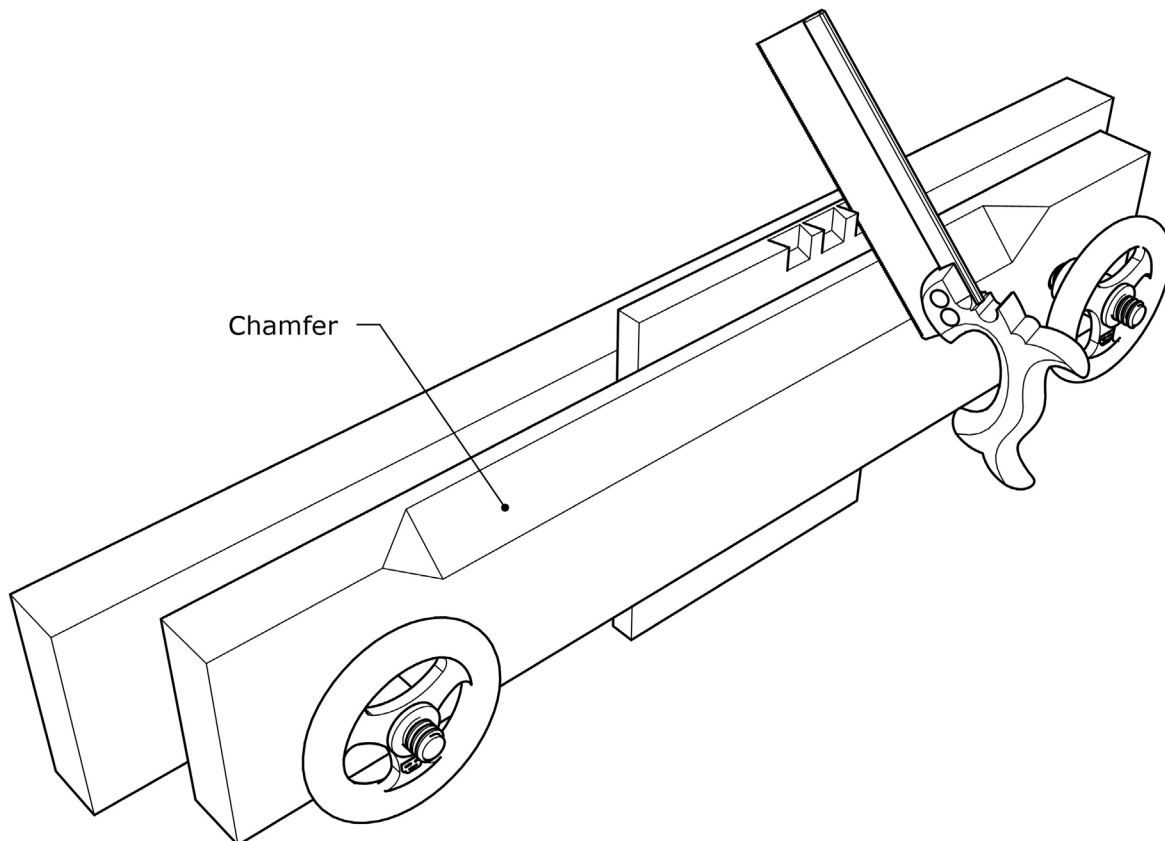

Adding a large chamfer to the movable jaw allows your saw to tilt down when cutting half blind dovetail pins. You can either run the chamfer completely across the length of the jaw, or to do a stopped chamfer, first cut a series of angled kerfs with a backsaw, break out the webs between saw cuts, then clean up the surface with a block plane.

FINISHING UP

The vise doesn't need to be finished, but it will stay clean longer and be nicer to use with a coat of oil or shellac. Don't apply finish to the inside of the fixed jaw, or to the bottom of the vise. You want these areas to stay grippy.

USING THE VISE

To use the vise for its most useful task--working the ends of boards narrow and wide as in dovetailing--place the closed vise on your benchtop and clamp the fixed jaw firmly to the benchtop at each end. If you have holdfasts, you can use these instead. If your bench is outfitted with a Benchcrafted Tail Vise or other wagon vise, and bench dogs positioned close to the front edge, you can trap the stabilizer between dogs and tighten the dogs firmly. Tap the dogs down with a hammer to bring the vise into firm contact with your benchtop.

To clamp a workpiece, first spin the wheels to open the jaws, insert your workpiece and slide it up to one of the screws (usually opposite your dominant hand). Spin the wheel until the jaw just touches the workpiece. You won't adjust this wheel again unless you change your workpiece thickness. Now center your workpiece between the screws and spin the other wheel. This will push the jaw up to the workpiece and clamp it securely. You won't need to tighten the vise further in most cases. Practice a few times to get a feel for how far you need to open the jaw to move the workpiece. When you open the vise, pull back on the workpiece to spread the jaws so when you reinsert another workpiece its quick and easy. When you have a whole chest of drawers to dovetail and you're moving numerous workpieces in and out of the vise, this sequence will translate into quick and effortless workholding. The vise is also excellent for cutting tenons.

BENCHTOP BENCH

You may wish to use your Moxon vise hardware to build a benchtop bench, or “bench on bench.” This miniature bench is clamped to your regular height bench and used in the same way as the standard Moxon vise. The work surface behind the fixed jaw allows you to clamp work directly to the top, transfer dovetail locations to your pin board, or keep small tools at the ready. A variety of different versions can be built with the hardware depending on your application. We provide a plan for a simple one in the measured drawings.

MOXON THE SHORT

You can build a shorter version of the Moxon vise with less distance between screws, perhaps 16”. This size is very handy for most drawer and small to medium size case work. It’s not often you need a full 24” capacity. Shorter Moxon vises are lighter and easier to store.

MAINTENANCE

The handwheels are made from cast iron, which will rust under the right circumstances. If your shop is not climate controlled, or you live in a particularly humid climate, you will need to take the same measures as with any steel or iron tool in your shop. There are many recipes for preserving cast iron. One uses equal parts boiled linseed oil and beeswax. Brush on a coat and wipe most of it off, leaving a thin layer. Let this dry overnight. You can also brush on a coat of shellac, or spray lacquer. Use your own judgment depending on your local conditions. We keep our test shop heated and air-conditioned year-round and we don’t have a problem with rust. The other parts of the vise being more highly polished are less susceptible to rust, but you should also take precautions with those as well. See our Moxon Vise FAQ for how to do the baked flax finish.

To keep the handwheels spinning freely its most important to keep the screws clean. A good brushing or blast of compressed air at the end of the

session should do it. You may find that a new handwheel will vibrate a bit if you spin it aggressively. First, go easy. A steady but positive spin is all you need (in actual use you don't spin the wheels so much.) Secondly, when we tap the threads in the handwheels' hub, the thread's profile is sharp and crisp. After a bit of use the cast iron threads will ease and the handwheel's action will get even sweeter. We recommend a few drops of drying type bicycle chain lubricant to keep the wheels running smoothly.

Text and measured drawings Copyright Benchcrafted 2022

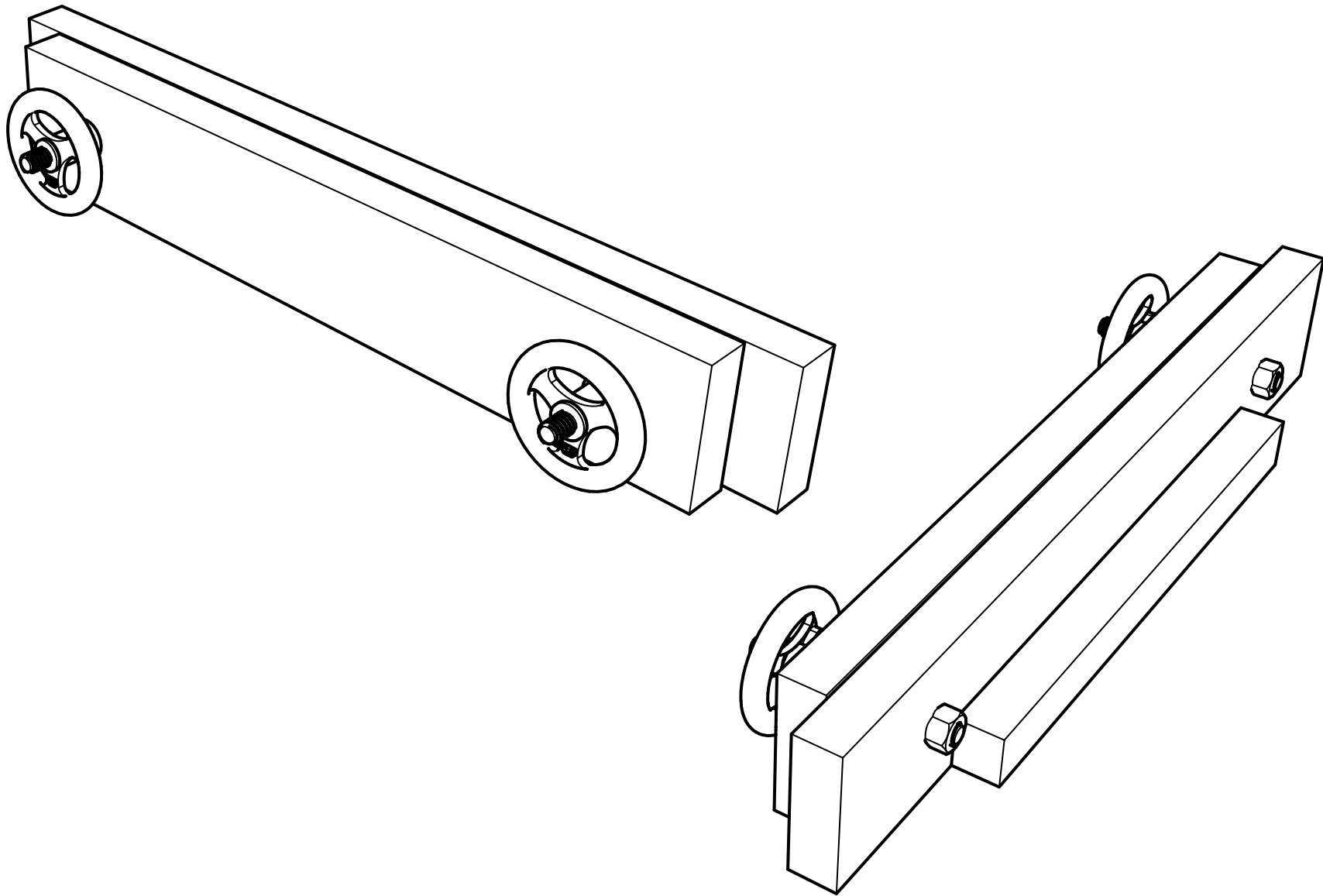

BENCHCRAFTED
MOXON VISE - Page 1

Copyright Benchcrafted. No unauthorized duplication without permission.



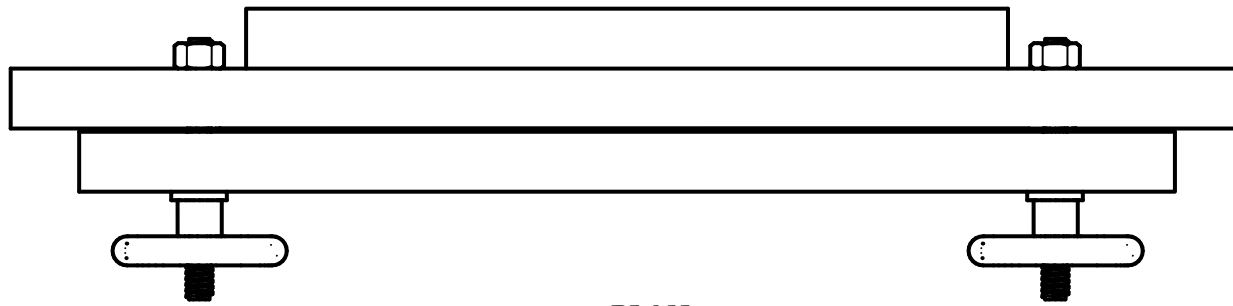

PLAN



FRONT

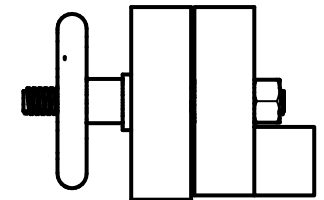

END

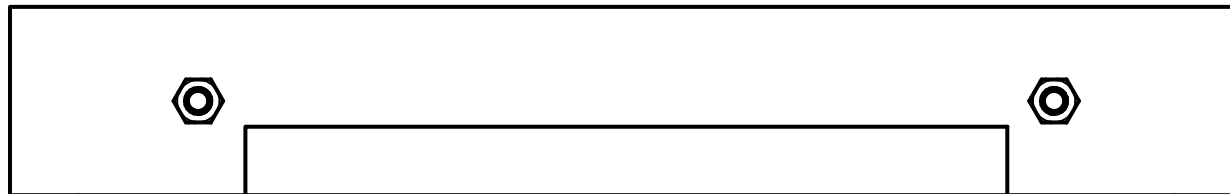

BACK



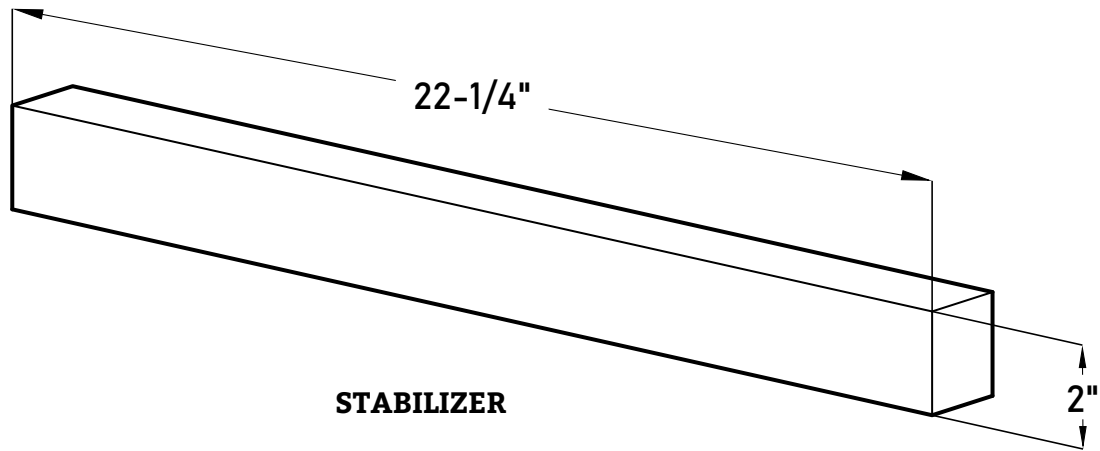

Note: All parts made from 1-3/4" stock

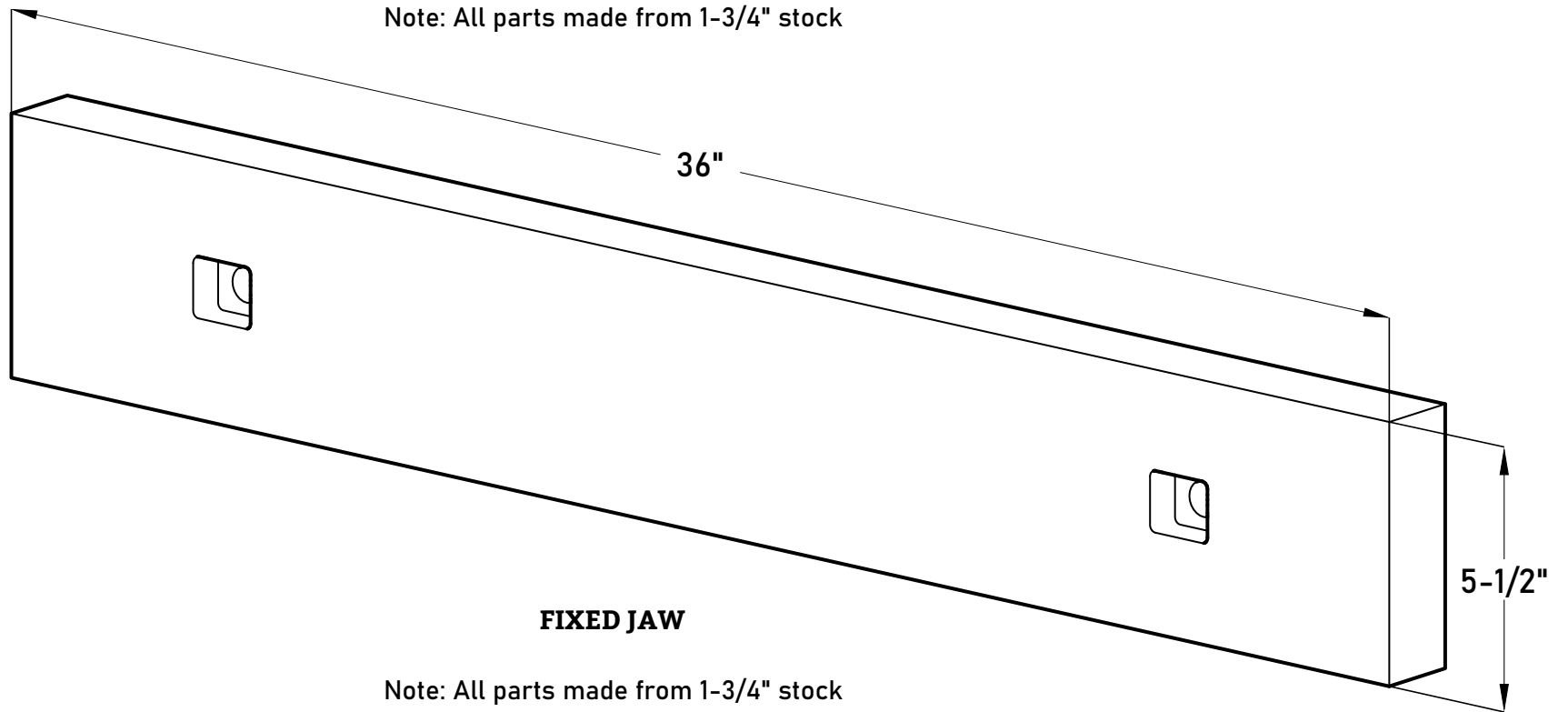

Note: All parts made from 1-3/4" stock



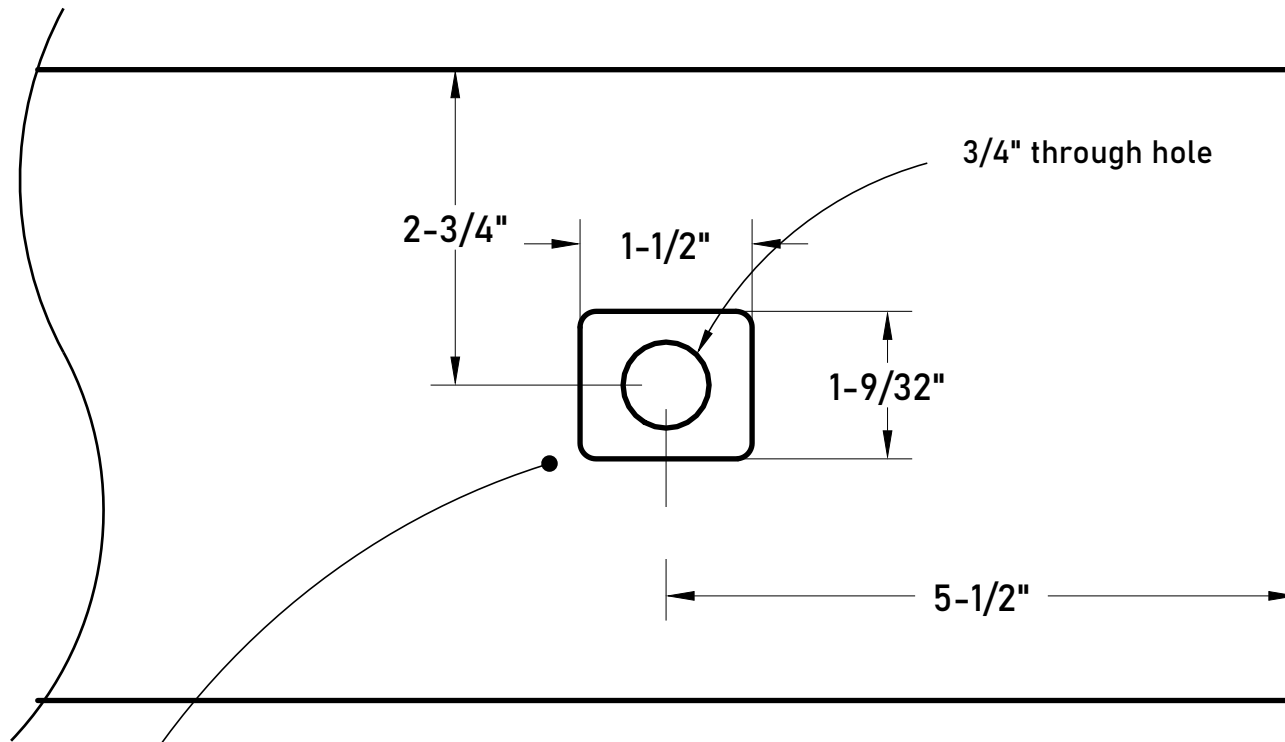

FIXED JAW DETAILS

Cut mortise for hex nut
and through hole for screw at both ends

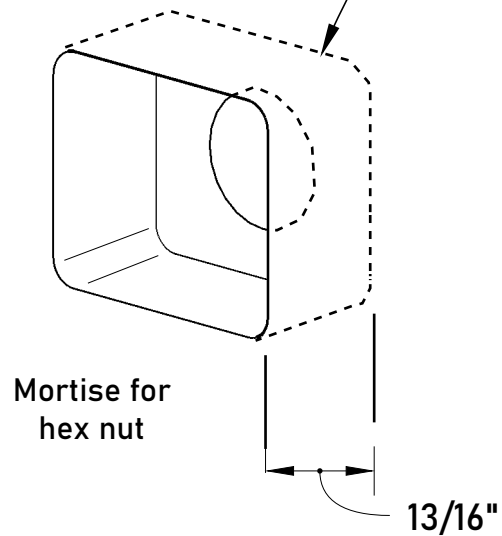

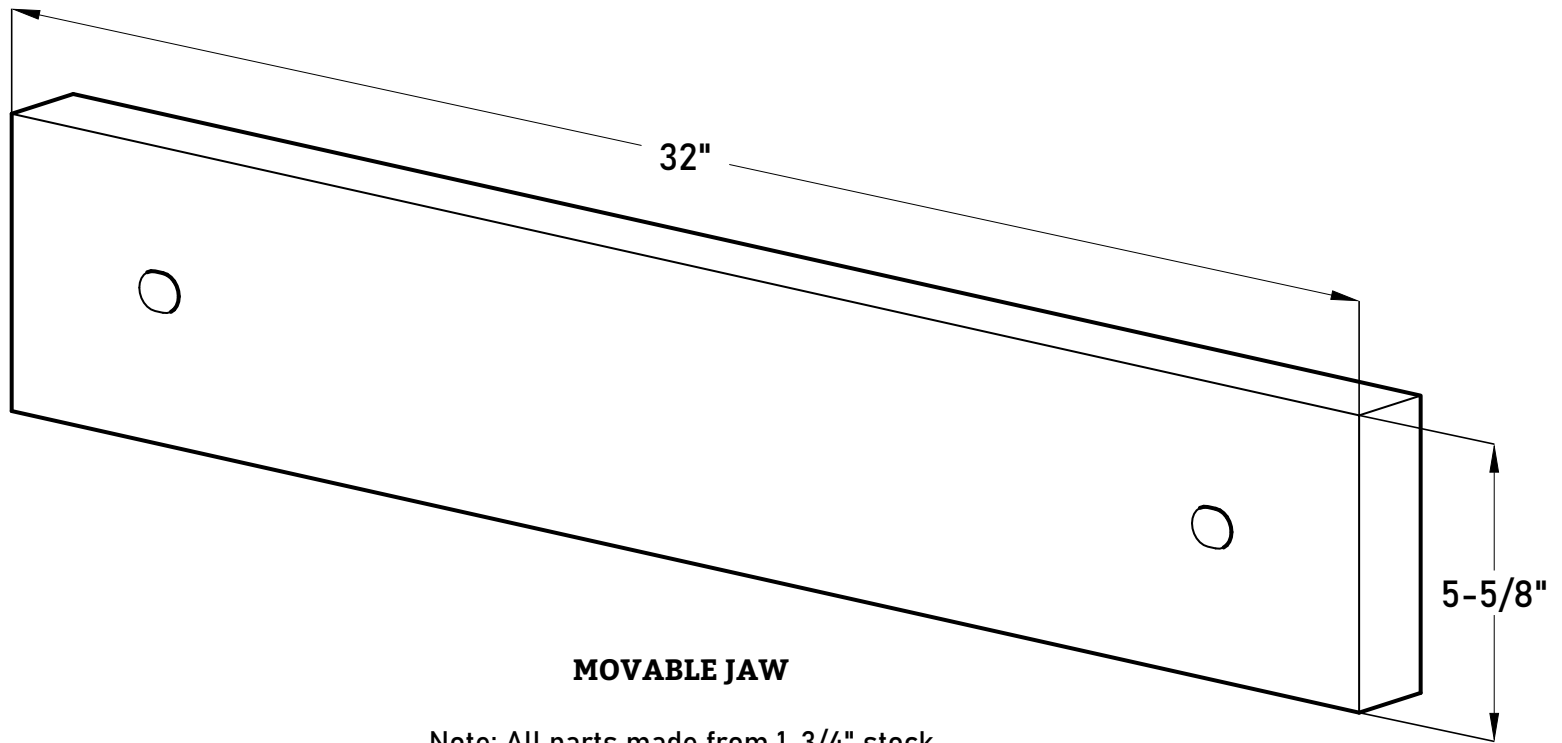

MOVABLE JAW

Note: All parts made from 1-3/4" stock

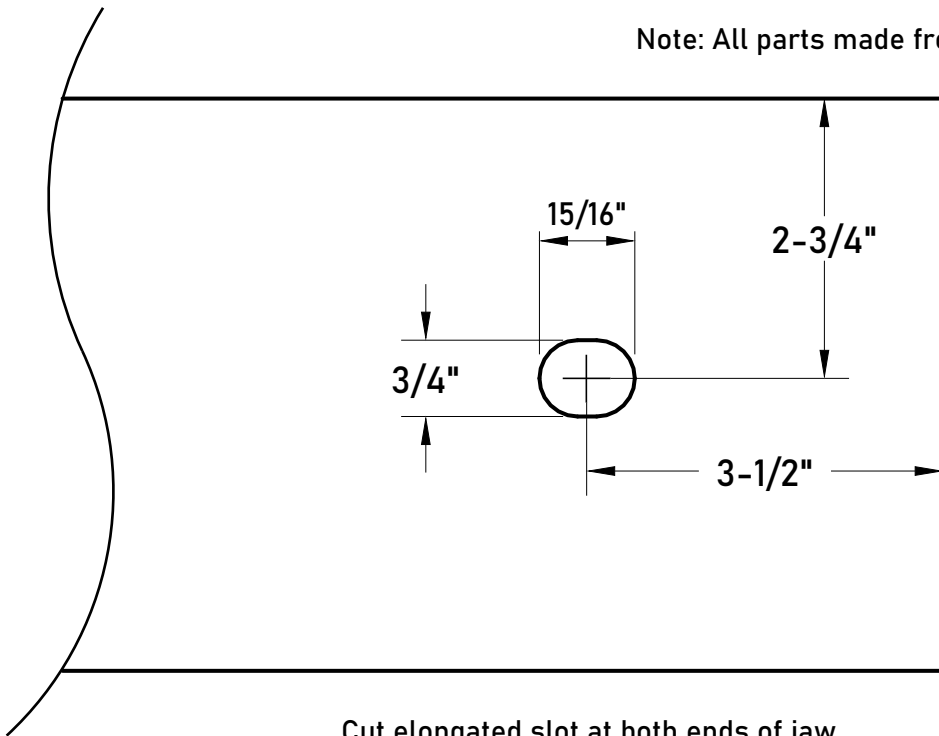

Cut elongated slot at both ends of jaw



Plans for a simple bench on bench. The large work surface aids in transferring dovetails to the pin board, or to hold tools while working.

Width and length of top are variable. Build what suits your workbench and style of work.

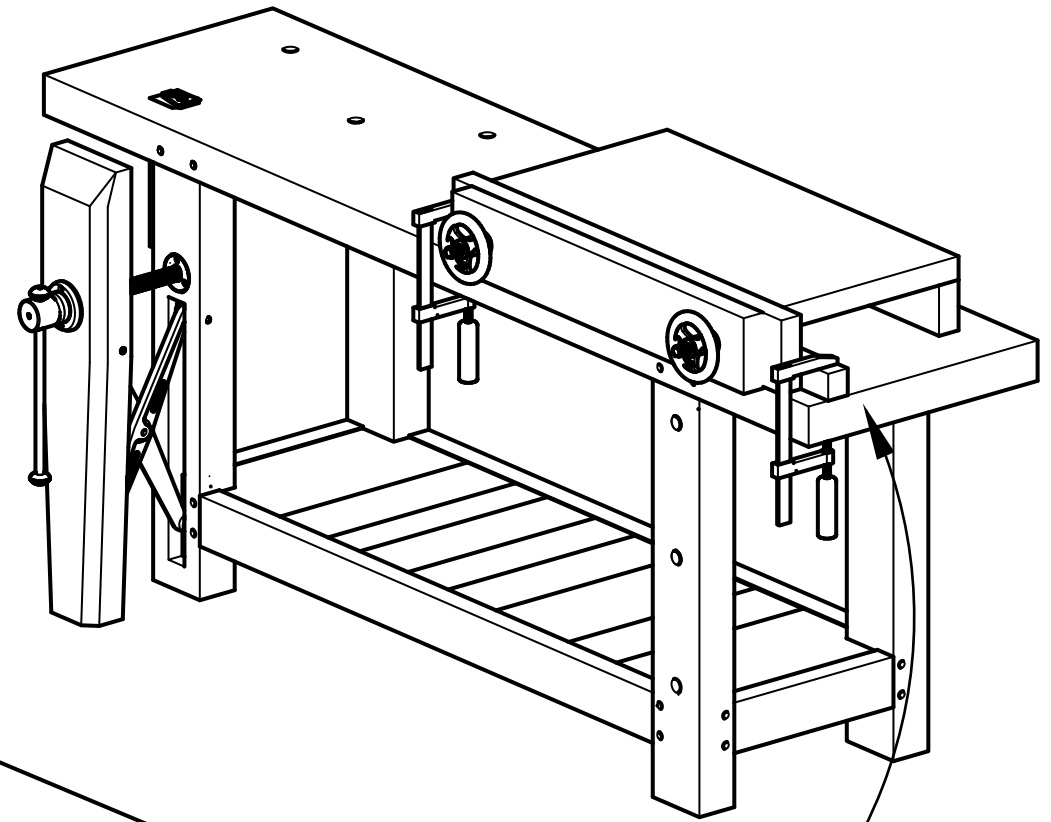
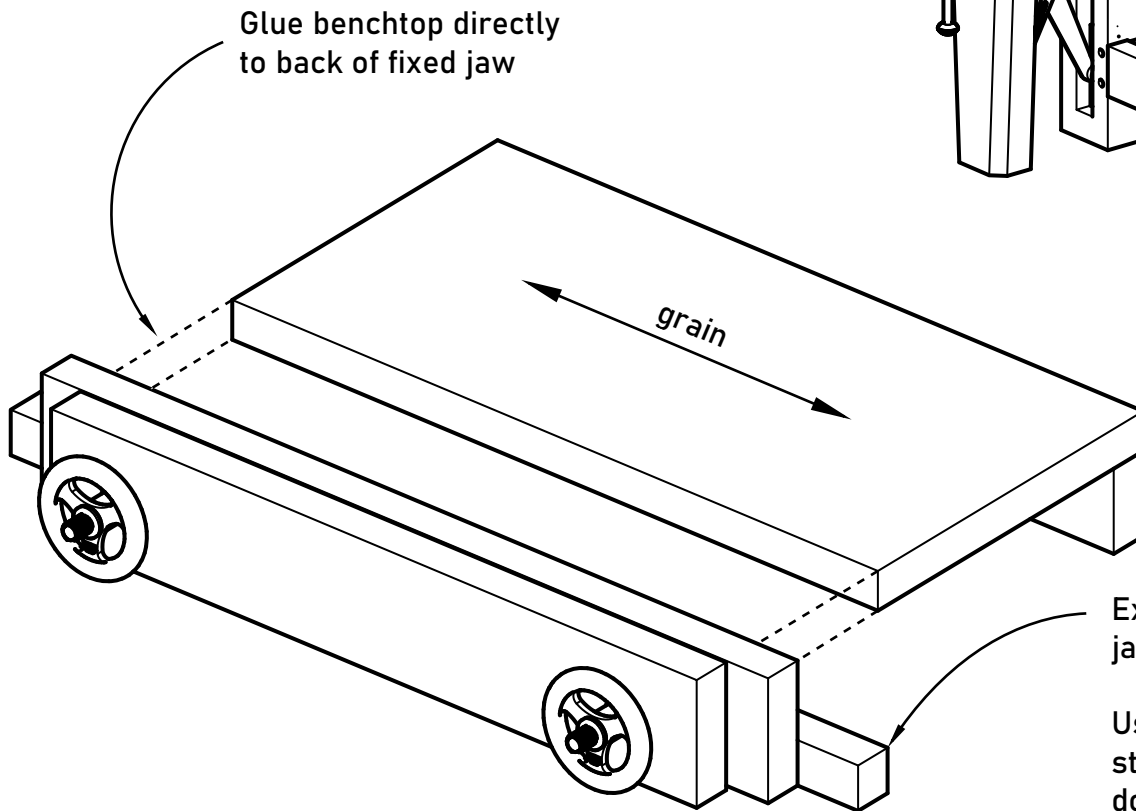

Extend stabilizer past fixed jaw as clamping point.

Use standard length stabilizer if your bench has dogs

BENCHCRAFTED
MOXON VISE - Bench on Bench

Copyright Benchcrafted. No unauthorized duplication without permission.

