

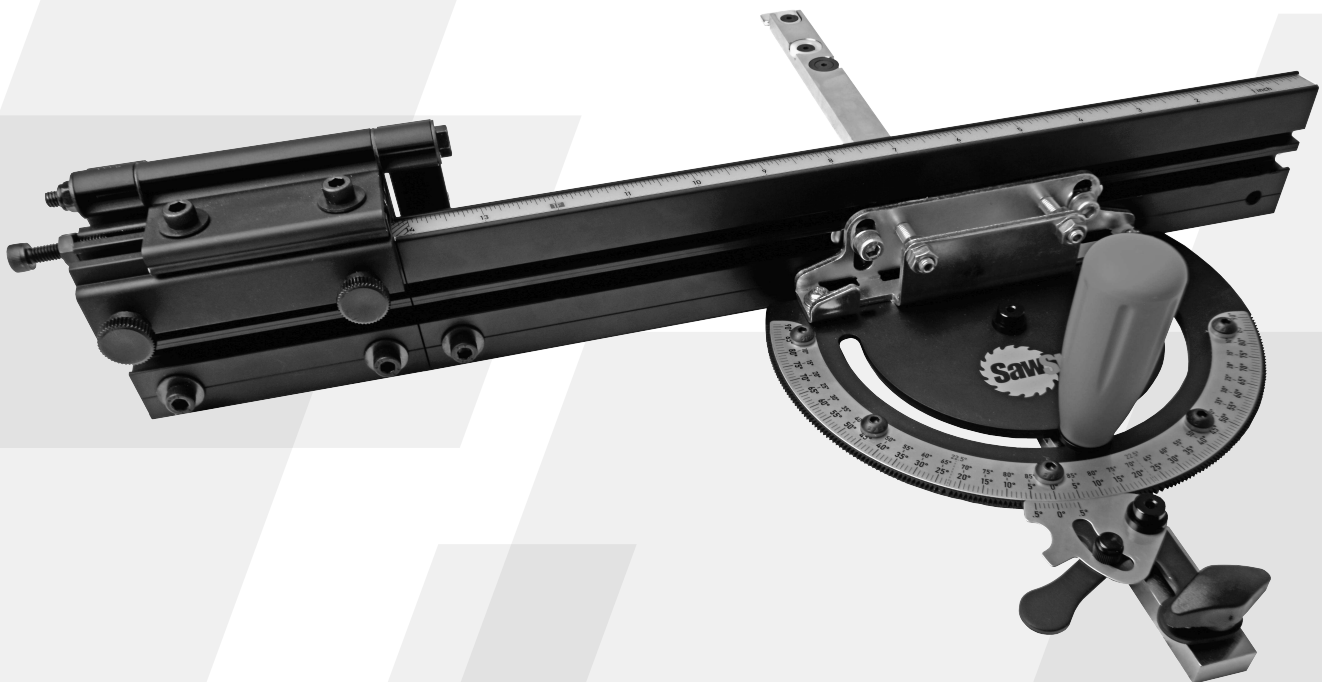

Model TSA-SMG-I

SCALE MITER GAUGE OWNER'S MANUAL



85-007802-00
Rev A - 08142024



www.SawStop.eu/support

- EN Additional translations of this manual are available from the above URL.
- IT Ulteriori traduzioni di questo manuale sono disponibili all'URL sopra indicato.
- NL Bijkomende vertalingen van deze handleiding zijn beschikbaar via de bovenstaande URL.
- SV Ytterligare översättningar av denna bruksanvisning är tillgängliga via ovanstående URL.
- FI Oppaan muita käännöksiä on saatavilla yllä olevasta URL-osoitteesta.
- DA Der kan findes yderligere oversættelser af denne vejledning på ovennævnte webadresse.
- NB Ytterligere oversettelser av denne håndboken er tilgjengelige på ovenstående internettadresse.
- PT Traduções adicionais deste manual estão disponíveis no URL acima.
- CS Další překlady tohoto návodu jsou k dispozici na výše uvedené adrese URL.
- PL Dodatkowe tłumaczenia tej instrukcji dostępne są pod powyższym adresem WWW.

Copyright SawStop, LLC
All Rights Reserved

Original Instructions - Scale Miter Gauge

Updates to this manual and additional related documentation such as exploded views and parts lists are available at SawStop.eu or SawStop.uk

SawStop and the SawStop blade logo are trademarks of SawStop, LLC.

TABLE OF CONTENTS

THANK YOU	4
SAFETY	4
ASSEMBLY AND INSTALLATION	4
REQUIRED TOOLS (included)	4
UNPACKING - WHAT'S IN THE BOX	4
T-SLOT DIMENSIONS AND COMPATIBILITY	5
ADJUST THE MITER BAR FIT	5
INSTALL THE GRIP AND T GUIDE	7
BASIC USE	7
SET THE MITER ANGLE	8
USING THE FENCE SYSTEM	11
USING THE DUAL FLIP STOP SYSTEM	13
CALIBRATION	16
SQUARE THE MITER ANGLE	16
SQUARE THE SCALE MITER GAUGE WITH YOUR SAW	18
ZERO THE FENCE RULER	18
TROUBLESHOOTING	22



THANK YOU

Thank you for purchasing the SawStop Scale Miter Gauge. We want you to get the most out of this product. To ensure the best possible experience, please read the instructions in their entirety prior to use. In this manual, you will find detailed instructions for the correct, accurate, and safe operation of your miter gauge.

SAFETY

- Be sure to wear hearing protection, eye protection, and follow all normal shop safety practices at all times.
- Before starting any cutting/milling operations with your Scale Miter Gauge, always securely tighten the large vertical grip/handle first.
- Secure all interfaces of adjustable, moveable parts of your miter gauge while it is in use or while it is being transported to or from the saw.
- Take care not to drop the miter gauge.
- Never let the saw blade or cutter in your machine come in contact with any component of your Scale Miter Gauge. Verify that nothing but the material you intend to cut or mill is in the path of the blade before turning on the tool.
- Keep the workpiece from moving during cutting. Always hold workpiece firmly to fence. This is especially important when cutting miters beyond 90°.
- Always make sure workpieces are properly supported.
- Never use the miter gauge in combination with a rip fence while cutting.
- Always take care to keep your hands clear of blade or cutter of the tool that you've chosen to use your miter gauge with.
- When using the flip stop accessory to position a workpiece for cutting/milling operations, always hold or otherwise secure the board against the miter gauge fence as you guide the workpiece past the cutter or blade.

- After re-positioning the fence, be sure the two hex head screws that secure the fence to the body of the miter gauge are sufficiently tightened.
- When adding a sacrificial fence to the miter gauge, take care to secure it firmly to the factory fence. Failure to do so can cause kickback and serious injury.
- Be aware of possible pinch risk when extending or retracting the fence extension.



IMPORTANT:

The scope of this manual does not include instructions for the machine you are using the Scale Miter Gauge with. These instructions assume you are competent and qualified in the safe and proper operation of the machinery you have chosen to accessorize with this miter gauge.

ASSEMBLY AND INSTALLATION

In this chapter, you will be instructed on how to unpack and prepare your Scale Miter Gauge for use.

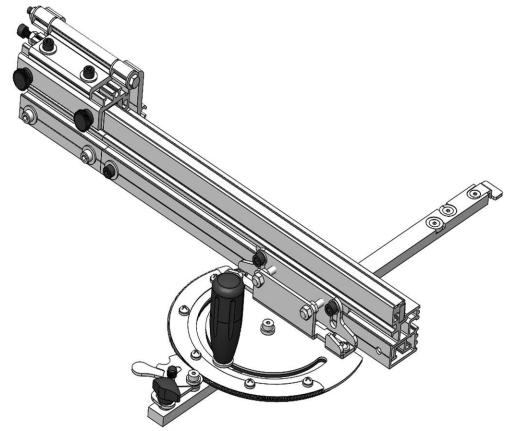

REQUIRED TOOLS (included)

- 3mm hex wrench (included)
- 5mm hex wrench (included)

UNPACKING - WHAT'S IN THE BOX

Included with your Scale Miter Gauge are the following items. Unpack your miter gauge and confirm that everything is accounted for.

- Miter gauge with extendable fence (pre-assembled)



- Dual flip stop
- Reverse ruler for main fence
- Reverse ruler for fence extension
- Parts bag containing:
 - Grip
 - T-clip with screw (use with T profile miter gauge slot)
 - 3mm hex wrench
 - 5mm hex wrench
 - (2) 38mm steel rods
- Spare parts bag containing:
 - (2) 12mm hex head screws w. (2) washers and (2) rectangular nuts
 - (3) Miter bar expansion discs
 - (3) Miter bar fixed discs
 - (3) Hex head screws for use with expansion or fixed discs

Your Scale Miter Gauge will function in most standard miter slots. The optional T guide (included) can be installed at the tip of the miter bar to take full advantage of machines equipped with T profile miter gauge slots.

i NOTE:

Though this product is capable of the multi-use versatility described above, this manual assumes the table saw use case where there are left and right miter gauge slots positioned on opposite sides of the blade. Be mindful that if your application differs, some of the instructions provided here may not apply and/or additional safety considerations may be required for your use case.

ADJUST THE MITER BAR FIT

Follow the instructions below to ensure the miter bar of your Scale Miter Gauge is optimally fitted to the miter slot in your machine. Perform this procedure prior to altering any other points of fine calibration discussed later in this manual.

! IMPORTANT:

The main assembly of your miter gauge is secured from movement during shipping with a hex head bolt (A). This bolt can be removed and discarded however **DO NOT DISCARD THE WASHER!(B)** Set it aside for assembly (described later in this manual).

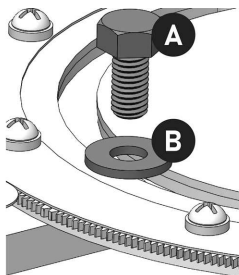

! IMPORTANT:

If the Scale Miter Gauge is moved between multiple tools in your shop (e.g. a table saw and bandsaw), be mindful that miter gauge slot dimensions may vary slightly between tools. When the miter bar fit is optimized for one machine, the fit may be less than optimal when used with a different tool. For best results, the steps described below should be repeated before using this miter gauge in a different machine than the tool for which the miter bar was previously fitted.

The *Miter Bar*, *Body* and *Fence* come pre-assembled. In the pages that follow, you will be instructed on the proper sequence of steps for installation and setup of the remaining pieces.

T-SLOT DIMENSIONS AND COMPATIBILITY

This product is primarily intended for use with a table saw for operations such as cross cutting and miter cutting. It can also be used with other machines equipped with a compatible T-slot such as a router table, bandsaw, shaper or stationary sander.

Steps for Adjustment

1. Place the miter bar into the slot of the machine you intend to use the Scale Miter Gauge with.
2. Using the provided 2.5mm hex wrench, loosen and then tighten each of the three discs along the length of the bar, being sure to bias the gap in the disc away from the opening in the bar.
 - Begin with the middle adjustment disc, then adjust the front disc. Adjust the disc at the rear of the miter bar last.
 - Adjusting the set screw in the clockwise direction will have the effect of increasing the width of the miter bar.

- Adjusting the set screw in the counter-clockwise direction will have the effect of decreasing the width of the miter bar.

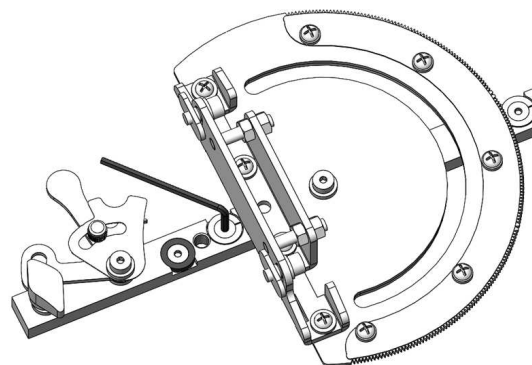
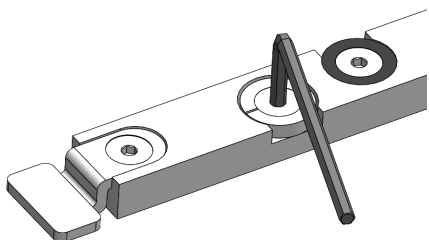

To access the rear adjustment disc, perform the following steps.

1. Remove the fence from the body of the miter gauge.
 - a. Using the provided 5mm hex wrench, loosen the bolts that join the miter gauge body to the fence.

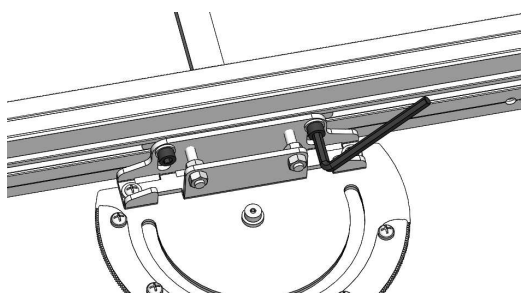

- b. Slide the fence off the guides and set the fence aside.
2. Rotate the protractor 180° as shown below.
 - a. If the *Grip* has already been installed, it must be removed for this adjustment.
 3. The third expansion disc is now exposed.
 4. Adjust the expansion disc as needed, rotate the protractor back to its normal operating orientation, and replace the fence.



IMPORTANT:

The optimal fit strikes a balance between minimizing side-to-side play of the miter bar while preserving easy travel of the miter gauge along the length of the miter slot. If the miter gauge offers too much friction when passing material across the table of your machine, loosen the adjustment described above to relieve the excessive friction.

If you're having trouble optimizing the fit, try using a piece of paper as a spacer between each adjustment disc and the side of the miter slot when performing this procedure.

Miter Bar Fit Still Not Right?

In most cases, by following the steps above, the SawStop miter gauge will be well fitted to your machine. However, if you find the fit to still be lacking, the instructions below will be of help.

Out of the box, your Scale Miter Gauge is outfitted with three, black, fixed guide-discs installed down one edge of the miter bar and three, white, expandable guide-discs down the other edge. This configuration accommodates most machines equipped with a standard miter slot.

Use the following variations when the fit does not meet expectations:

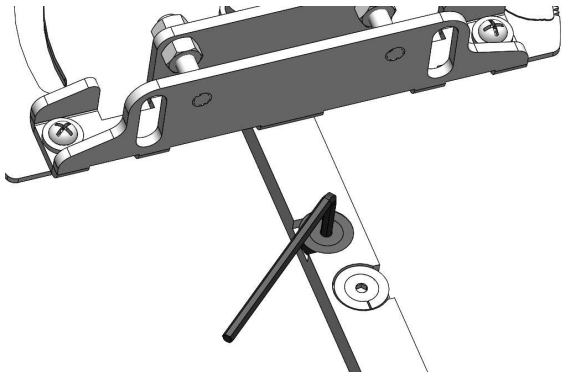

When the miter bar fit is too tight, consider removing the black, fixed, guide-discs from the miter bar.

When the miter bar fit is too loose, consider replacing the black, fixed, guide-discs with white expansion discs. (Three, spare expansion discs are included with your miter gauge in the parts bag.)

For either scenario, adjustment of the expansion discs will likely be required. See the instructions found earlier in this chapter. Whatever mixture of guide discs you choose to install, be sure to keep the spare discs in a safe place should the installed guide discs become worn and need replacing in the future.

INSTALL THE GRIP AND T GUIDE

1. Place the flat washer you removed during unpacking (described above) over the threads indicated in the image below.
2. Install the grip onto the threads as shown.

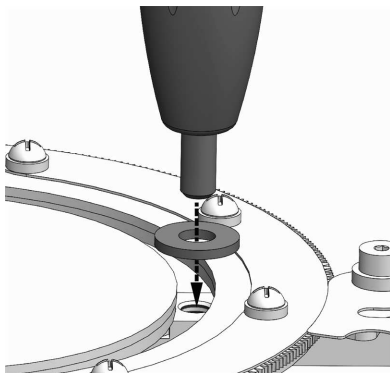

3. If your machine is equipped with a "T" shaped miter slot, install the T guide at the tip of the miter bar using a 5mm hex wrench.

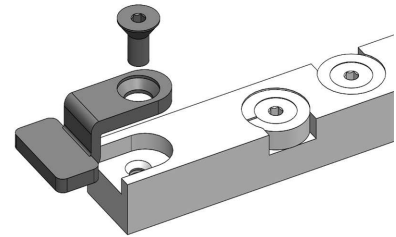

BASIC USE

This portion of the manual discusses basic use of your Scale Miter Gauge such as setting the miter angle, using the fence system, and how to use the adjustable flip-stop system. The main controls on your Scale Miter Gauge are labeled in the next illustration. These controls are referenced by name in the instructions that follow.

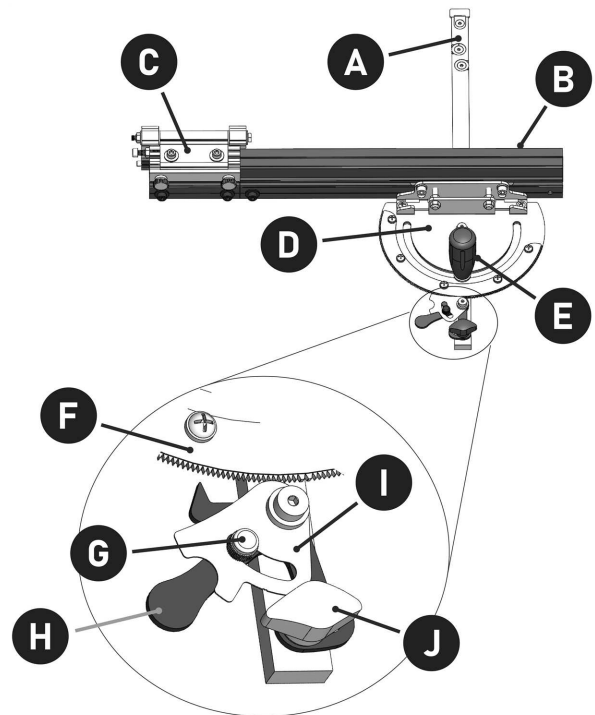

- | | |
|-------------------------|------------------------------|
| A. Miter Bar | F. Protractor |
| B. Fence | G. Pivot Cursor Locking Knob |
| C. Adjustable Flip Stop | H. Pivot Actuator |
| D. Body | I. Pivot Cursor |
| E. Grip | J. Actuator Locking Knob |

SET THE MITER ANGLE

Follow the steps below to change the miter angle on your Scale Miter Gauge for whole degree increments.

1. Loosen the *Grip* and the *Actuator Locking Knob* slightly by turning them counter-clockwise.

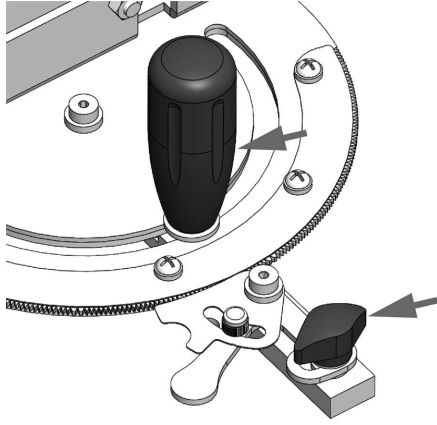

2. Pull the *Pivot Actuator* toward you to release its tooth from the mating detent on the *Protractor*.

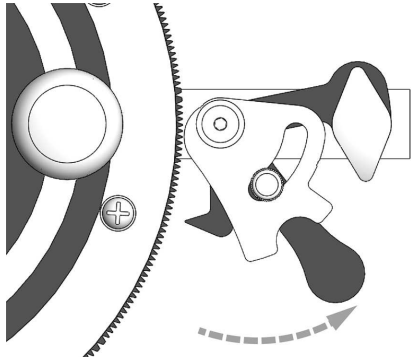

3. Rotate the protractor body and fence to the desired angle, aligning the protractor marks with the 0° mark on the *Pivot Cursor*.
4. Push the *Pivot Actuator* forward again to firmly engage its tooth into the mating detent on the *Protractor*.

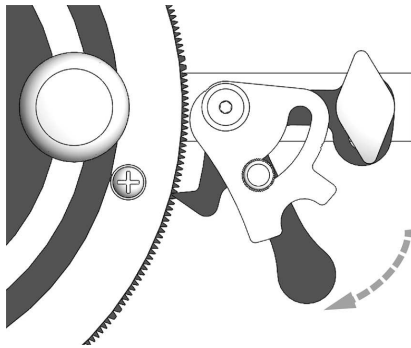

5. Re-tighten the *Grip* and the *Actuator Locking Knob* by turning them in a clockwise direction to secure your selected miter angle.

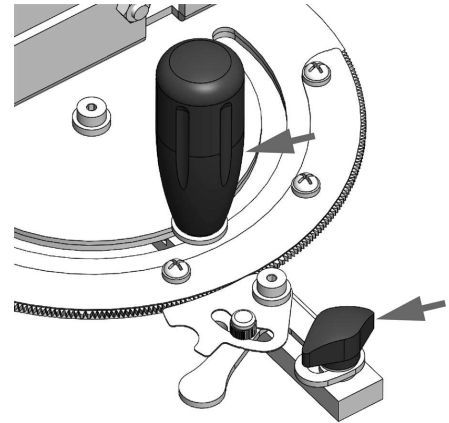

i NOTE:

The protractor of this miter gauge has an additional detent at 22.5° making the above method applicable when this miter angle is needed. For all other fractional degree angle settings, refer to the fractional degree method below.

Set a Fractional Degree Miter Angle

Should you require a miter angle finer than whole degree increments (as described above), use the following steps.

1. Loosen the *Grip* and the *Actuator Locking Knob* slightly by turning them counter-clockwise.

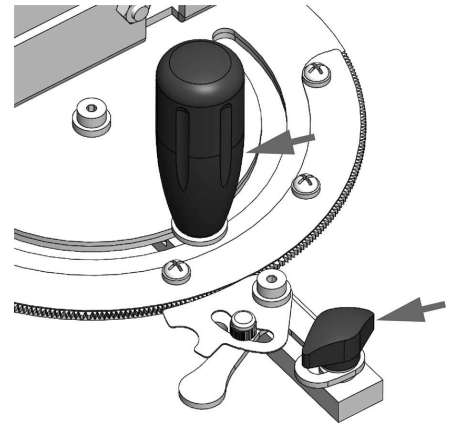

2. Pull the *Pivot Actuator* toward you to release its tooth from the mating detent on the *Protractor*.

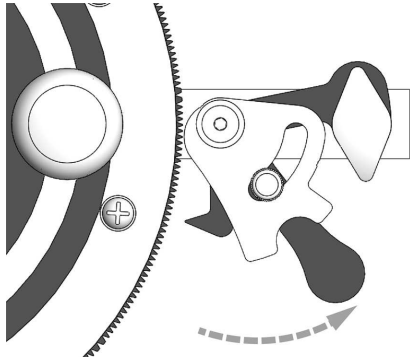

3. Loosen the *Pivot Cursor Locking Knob* (A) by turning it counter-clockwise. The vernier scale from which the miter angle is read (*Pivot Cursor*) can be pivoted forward again to rest against the protractor.

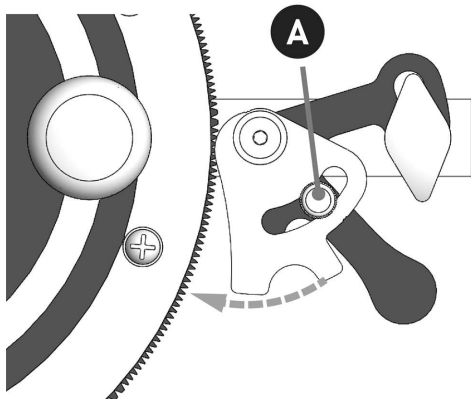

4. Secure the *Pivot Cursor Locking Knob* again by turning it clockwise.
5. Rotate the protractor body and fence to the desired angle. See below for details on Reading the Vernier Scale to achieve $1/10^\circ$ increment accuracy.
6. **DO NOT** push the *Pivot Actuator* forward again. Engaging its tooth with the mating detents in the protractor will shift your miter adjustment to the nearest whole degree increment.

7. Re-tighten the *Grip* and the *Actuator Locking Knob* by turning them in a clockwise direction to secure your selected miter angle.

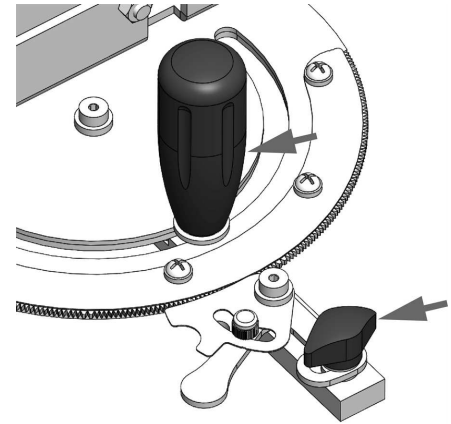

Reading the Vernier Scale

The *Pivot Cursor* (B) of your miter gauge features a vernier scale with 5 additional marks to the left and right of the 0° mark. Reference these additional markings as follows to achieve fractional degree accuracy with setting miter angles.

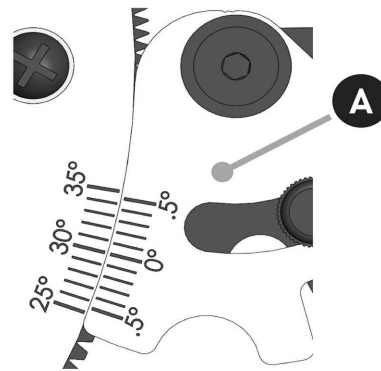

Vernier Scale Examples

The examples below assume you need to cut a left 30.n° miter where n = the fraction of 1/10°, 2/10°, 3/10° and so forth.

To achieve this angle	Align this mark on the protractor...	...with this mark on the vernier scale.	This is how it looks
30°	30	0°	
30 1/10°	31	The first mark RIGHT of 0	
30 2/10°	32	The second mark RIGHT of 0	
30 3/10°	33	The third mark RIGHT of 0	
30 4/10°	34	The fourth mark RIGHT of 0	
30 5/10°	35	The ".5°" mark RIGHT of 0	
30 6/10°	27	The fourth mark LEFT of 0	
30 7/10°	28	The third mark LEFT of 0	

USING THE FENCE SYSTEM

The 18 inch (457mm) fence on your Scale Miter Gauge offers extended support for bigger material but also has some added benefits. Those additional features and how to use them are discussed below.

Setting Safe Fence Distance from Blade

To ensure maximum support of the workpiece, position the fence to run close to the blade where friction on the workpiece is greatest during cutting operations. Be sure there is an adequate margin for safety.

1. With the machine powered off, place the miter gauge into the miter slot of your machine. After setting the desired miter angle, move the miter gauge down the length of the miter slot and confirm that no part of the fence is in the path of the blade.

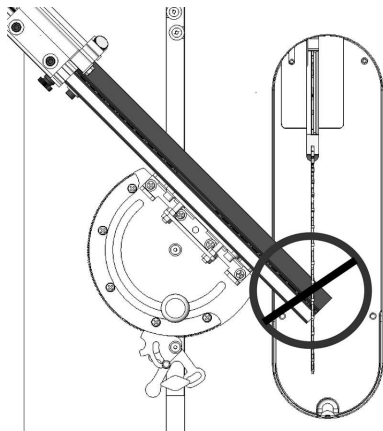
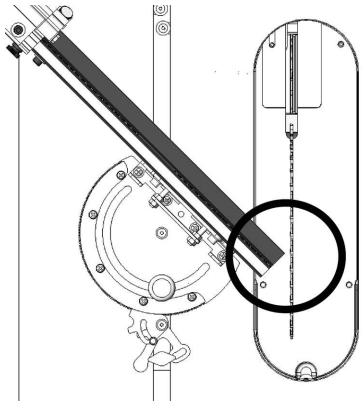

2. Adjust the fence to the left or right as needed to ensure an adequate margin of safe distance between the fence and blade is achieved.

- a. Using the provided 5mm hex wrench, loosen the cap screws on the back side of the miter gauge body shown below.

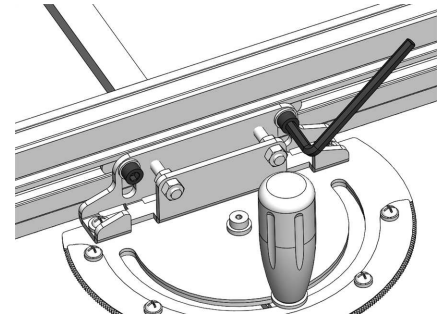

- b. The fence is now freely moveable. Reposition the fence as needed for safety.
- c. Secure the cap screws loosened in step a.



WARNING:

If you change the miter angle, the clearance between the fence and blade may also change. To minimize risk of injury and damage to your miter gauge, re-confirm that a safe margin of clearance is present (described above) after any miter angle adjustment is made.

Using the Fence Extension

For additional workpiece support, your Scale Miter Gauge has a telescoping feature that extends the fence up to an additional 13 inches (330mm). Use the following steps to extend the fence.

1. Using a 5mm hex wrench, loosen the socket head bolt shown.

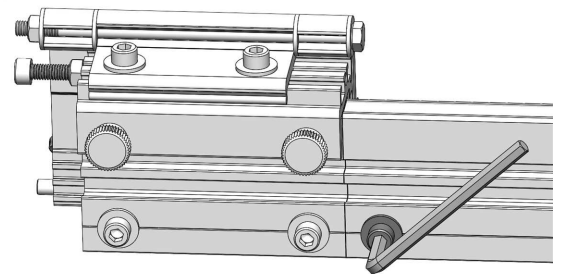

2. The telescoping fence extension now slides freely. Pull the fence extension to the desired length.

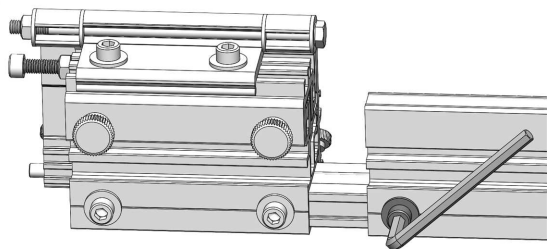

3. Re-secure the fence extension retention bolt using the supplied 5mm hex wrench to fix the extension at the selected position.

Reversing the Fence Extension

The fence extension can be configured to accommodate use of the Scale Miter Gauge in either the left or right miter slots of your table saw. The extension should be positioned into the end of the main fence extrusion that is furthest from the blade. Use the steps below to reconfigure the fence extension. This instruction assumes the fence extension is currently configured for use in the left miter slot but setup for use in the right miter slot is now desired.

1. Using the supplied 5mm hex wrench, loosen the socket head bolt shown.

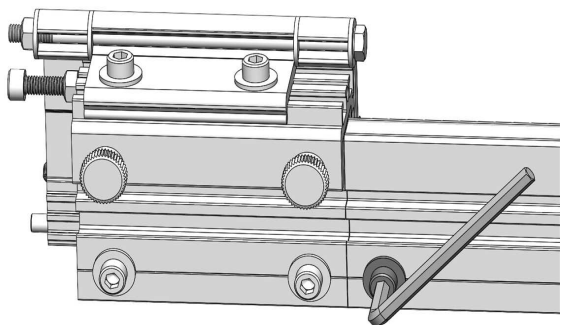

2. Pull the fence extension out and completely free of the main fence extrusion.

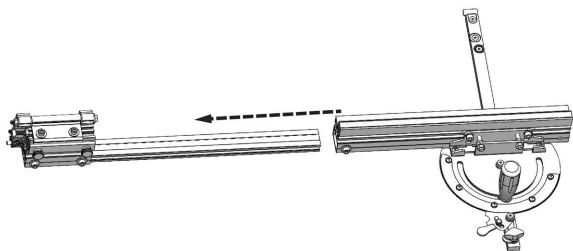

3. Remove the socket head bolt, washer and rectangular nut that rides in the T-track of the telescoping extension. Next, move this hardware to the corresponding hole at the opposite end of the main fence extrusion.

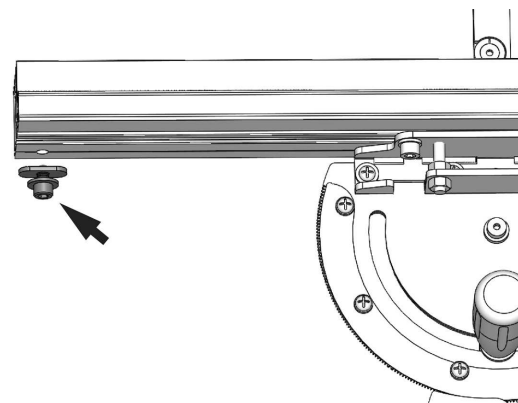

4. Insert the extension (A) into the opposite end of the main fence extrusion (B). Take care to align the rectangular nut (C) you re-located in the previous step with the T track of the extension as it is being inserted.

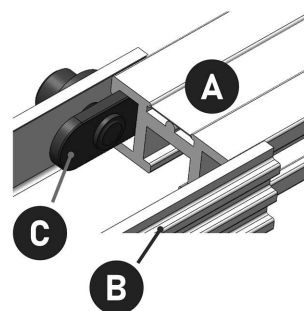

(Fence illustrated above as cut-away view.)

5. If desired, replace the ruler in the main fence extrusion with the included reverse ruler. To remove the current ruler, slide it down the length of the slot in which it is fitted and install the alternate ruler in its place by feeding it into the end of the extruded slot.

If desired, replace the lower ruler in the extension with the included reverse ruler. The lowest numbers on this ruler should be positioned furthest from the blade. To remove the current ruler, slide it down the length of the slot in which it is fitted and install the alternate ruler in its place by feeding it into the end of the extruded slot.

! IMPORTANT:

If you have performed the instructions at **ZERO THE FENCE RULER** on page 18 of the **CALIBRATION** chapter, reversing the extension and/or replacing the rulers as above will require that this calibration procedure be repeated.

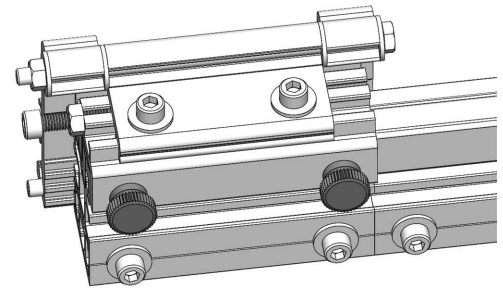

6. Adjust the extension to the desired length and secure the selected position by tightening the socket head bolt with the supplied 5mm hex wrench.

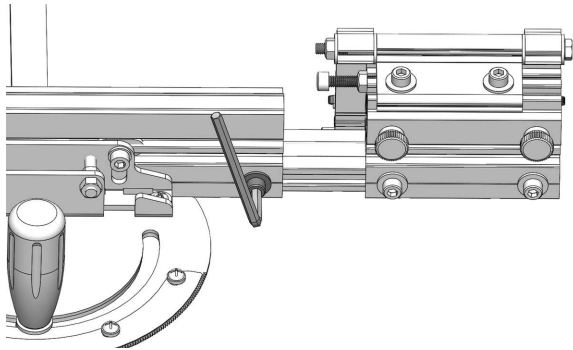

USING THE DUAL FLIP STOP SYSTEM

The adjustable flip stop included with your Scale Miter Gauge offers convenience and precision for making repeat cuts of the same lengths. Use the following instructions to take full advantage of the flip stop system.

Position the Dual Flip Stop - Gross Adjustments

The carriage on which the dual flip stop is mounted can be re-positioned along the T-slot in the top of the fence by using the following steps.

1. Loosen both nylon thumbscrews on the back of dual flip stop assembly at least one full revolution. Push the flip stop carriage forward slightly before moving it from its current location along the top of the fence.

2. Position the dual flip stop at the distance from the blade or cutter of your machine for the length of cut you want.

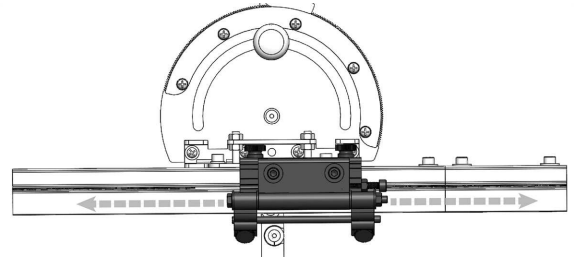

3. Secure the selected position of the dual flip stop assembly by re-tightening the nylon thumbscrews on the back of the dual flip stop assembly. DO NOT over-tighten.

! IMPORTANT:

To ensure accurate readings from the ruler attached to the fence of your Scale Miter Gauge, be sure to visit the **CALIBRATION** chapter of this manual and read **ZERO THE FENCE RULER** on page 18 for instructions.

Position the Dual Flip Stop - Fine Adjustments

The fine adjustment feature for the flip stop of your Scale Miter Gauge allows for a lighter touch that is sometimes not achievable with the above method for positioning the flip stop. Use the following steps to take advantage of this precision feature.

1. Set a rough position of the flip stop following the instructions for **Positioning the Dual Flip Stop - Gross Adjustments** above.

- Loosen the socket head bolts indicated in the illustration below.

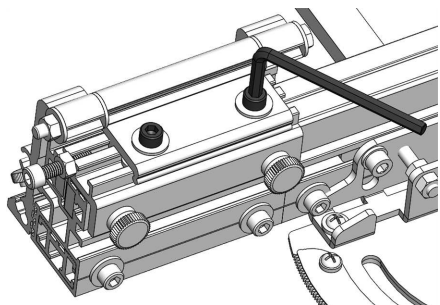

- Loosen the nylon nut for the fine adjustment bolt shown. (No tools required.)

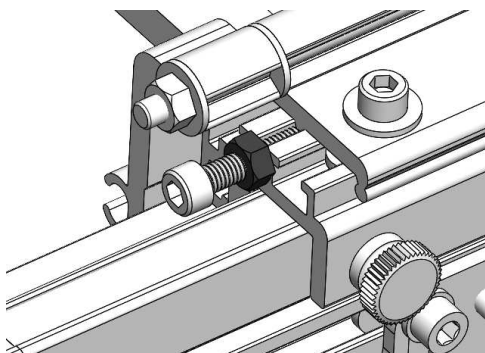

- By turning the fine adjustment bolt (highlighted in the illustration below) you can shift the position of the dual flip stop to the left (counter-clockwise) or the right (clockwise).

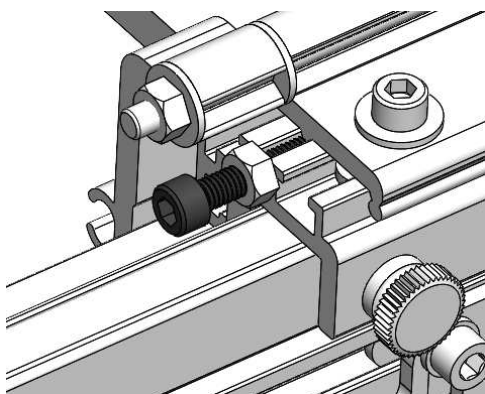

- When the desired position of the flip stop is set, re-tighten the nylon nut for the fine adjustment bolt (shown in step 3). Use no tools here. Just finger tight is sufficient.
- Re-tighten the socket head bolts that were loosened in step 2.

Using the Flip Stop Arms Independently

The dual flip stop on your Scale Miter Gauge is actually two stops in one.

By shifting or removing the length of steel rod at the bottom of the flip stop, individual arms can be de-coupled so they can be independently employed or retracted.

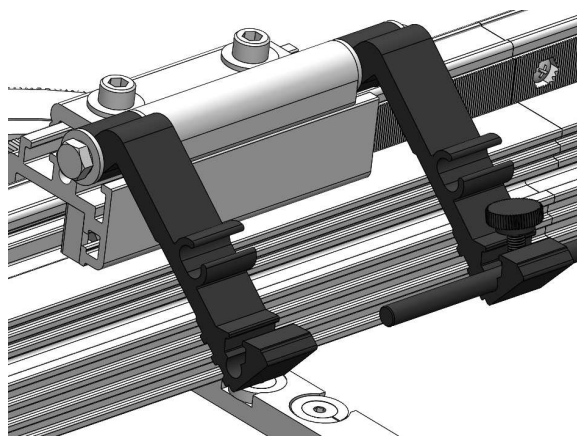

This ability enables you to establish stops for multiple cut lengths with setting the position of the stop carriage just once. Follow the steps below for setting cut length positions for each, individual flip stop.

Depending on the cuts you need, the length of steel rod can now be removed completely and set aside.

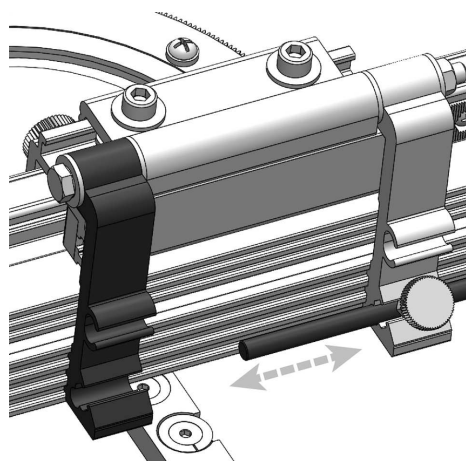

Alternatively, you can re-position the long steel rod in either of the flip stop arms (slide it left or right) and secure it in place by just one of the thumb screws (as shown above). The tip of the rod then becomes the stop for your workpiece.

For still more flexibility, two shorter (38mm) rods are included with your Scale Miter Gauge that can be positioned and secured with the thumbscrews as needed using the same methods described above.

1. Loosen both thumb screws (A) located near the tip of the flip stop arms.

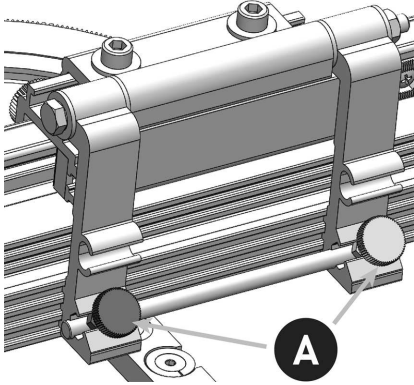

! WARNING:

When your chosen setup results in one or both thumb screws not engaged with the adjustable stop rod, take precautions to secure them from coming loose during cutting operations. Options include (B) securing the thumbscrew in its normal location (even though the rod is absent), remove the thumb screw completely and set it aside, or (C) secure it in its storage slot as shown below.

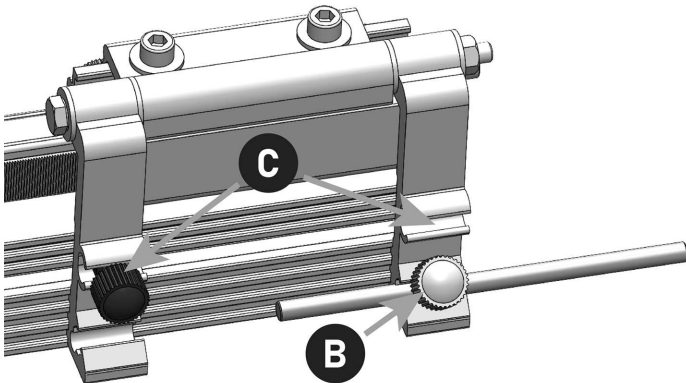

The dual flip stop arms are independently hinged such that they can now be lowered or retracted as needed for either of the two stop lengths you've just set. Alternatively, retract both arms to accommodate a workpiece that requires the support of full length of the fence and beyond.

Using the Dual Flip Stop With a Sacrificial Fence

! WARNING:

When adding a sacrificial fence to the miter gauge, take care to secure it firmly to the factory fence. Failure to do so can cause kickback and serious injury.

Adding a suitable material (D) (not included) secured to the front of the aluminum fence (E) of your Scale Miter Gauge can be done by taking advantage of the T-slot that runs the length of the face of the fence. A pair of M6x19mm bolts with M6 rectangular nuts (F) are also required (not included).

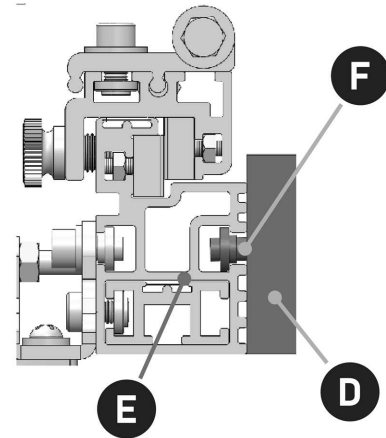

Among other advantages, this optional modification adds versatility to your fence system including:

- Extends the length of your fence to provide additional support for bigger workpieces.
- After securing the sacrificial piece and making an initial cut, there is now a visual reference for where the blade passes through. This is helpful for aligning a workpiece for the next cutting operation.
- When making cuts, the waste to the right of the blade is supported and safely moved past the blade. This is applicable when the depth of cut is less than the height of the sacrificial fence. (Were the blade height set too high, the sacrificial fence material past the blade would be cut completely off.)

The dual flip stop can be used in conjunction with this modification if the added material does not exceed the height of the aluminum fence and 3/4" (19mm) thickness.

When employing a sacrificial fence with your Scale Miter Gauge, the dual flip stop can still be used but it must first be repositioned from the rear slot (G) of the flip stop carrier extrusion to the forward slot (H).

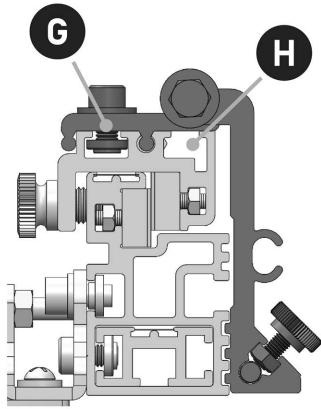

Perform the following steps to move the flip stop for use with a sacrificial fence (D).

1. Loosen the socket head bolts indicated in the image below.

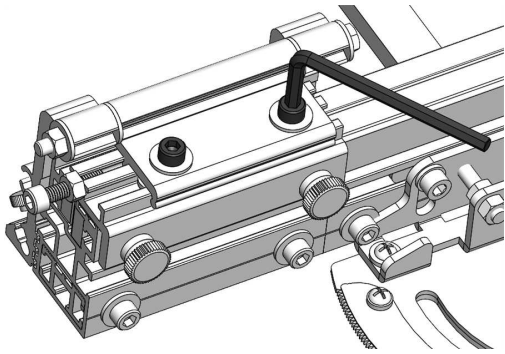

2. Slide the flip stop out of the rear T-slot of the carrier and move it to the forward slot.

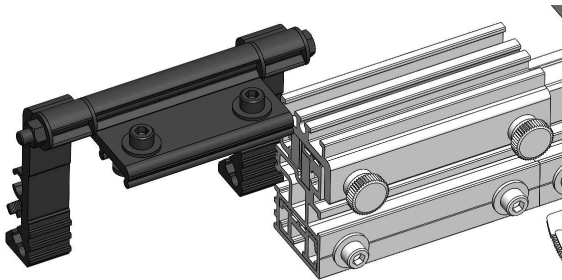

3. Tighten the socket head bolts you loosened in step 1.

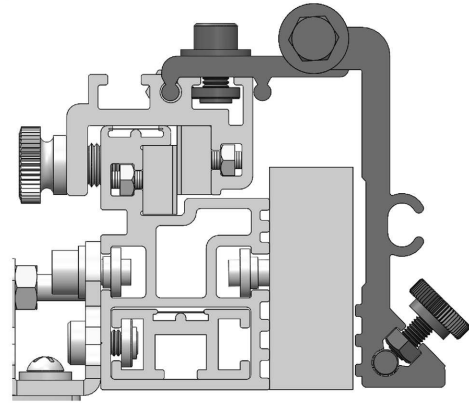

Reassembly is now complete. The above image shows the flip stop in the forward slot of the carrier to provide the necessary clearance for the sacrificial fence (also shown).



IMPORTANT:

If you have performed the procedure described in **ZERO THE FENCE RULER** on page 18 of this owner's manual, moving the dual flip stop as described above will require that this calibration procedure be repeated.

CALIBRATION

Your Scale Miter Gauge comes precision made by SawStop and is fully functional straight from the box. With the need for various fine adjustments to be made by the end user in mind, your miter gauge has been engineered to be calibrated in various ways. Instructions for these adjustments are discussed below.

SQUARE THE MITER ANGLE

Your SawStop Scale Miter Gauge should arrive already calibrated and square out of the box. Follow the steps below if you find that adjustment is needed.

1. Using the included 5mm hex wrench, loosen the socket head bolts indicated in the image below and remove the fence extrusion from the miter gauge body.

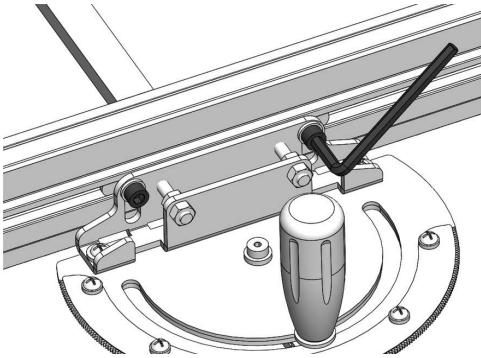

2. Set the miter angle to 0°.

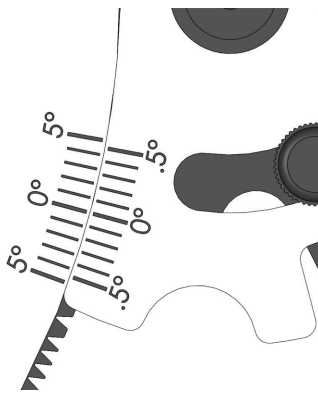

3. Engage the *Pivot Actuator* with the protractor.

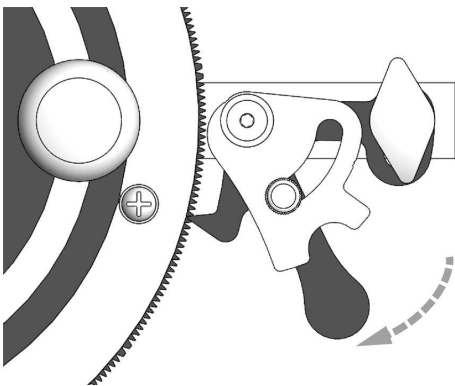

4. Tighten the *Grip* and the *Actuator Locking Knob*.

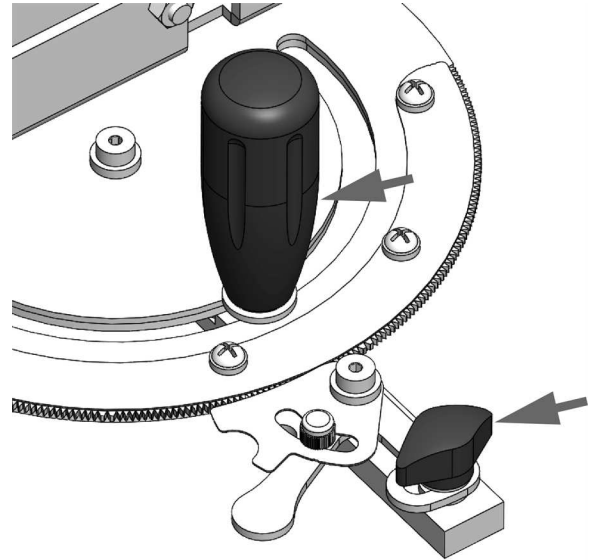

5. Remove your Scale Miter Gauge from the miter slot of your saw and remove guide disc from the miter bar as shown.

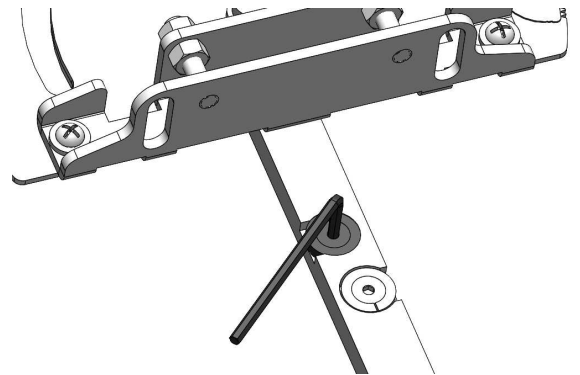

6. Using a precision reference square, align the fence against the *Miter Bar* and the fence head.

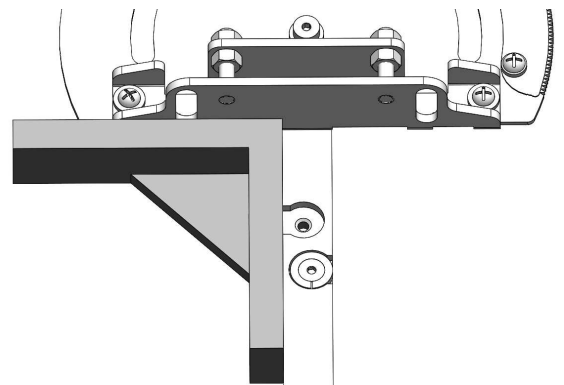

7. Using the square positioned at both the left and right side of the *Miter Bar*, assess whether the

miter gauge is out of square. If there is any gap or light between the blade of the square and the fence head or *Miter Bar*, perform the following steps to correct this:

- a. Loosen the four Phillips head screws that secure the miter gauge head to the base. This introduces a small amount of play between these two components of the miter gauge assembly.

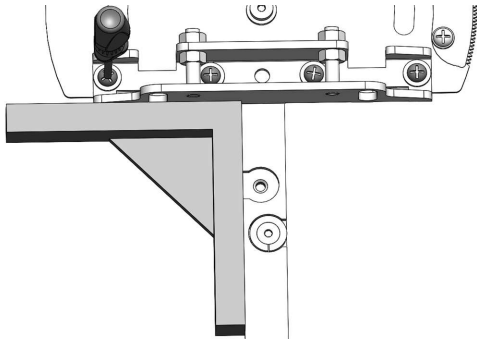

- b. Square the fence head to the *Miter Bar* using a precision reference square as shown above, then re-tighten the four Phillips screws you loosened in step a.
- c. Double-check your Scale Miter Gauge for squareness after re-tightening the screws. Loosen the screws and re-adjust as necessary until you are satisfied with the accuracy.
- d. When finished, replace the fence extrusion onto the Scale Miter Gauge body and replace the guide disc you removed in step 5.
- e. Verify that all fasteners adjusted during this process are tight.

SQUARE THE SCALE MITER GAUGE WITH YOUR SAW

1. Confirm the blade of your saw is parallel to the miter gauge slot of your saw. Adjust the saw trunnion or table as needed per the instructions provided by the manufacturer of your tool.
2. If needed, perform the steps in the previous section, **Squaring The Miter Angle** to ensure the fence of the Scale Miter Gauge is perpendicular to the miter bar.
3. With the power off and saw unplugged, raise the blade to full height.

4. Use a precision reference square against the flat of the blade and your Scale Miter Gauge to check for squareness.



IMPORTANT:

Ensure that the contact between the reference square and the blade is limited to the flat of the blade. Avoid registering the square against saw blade teeth as this will skew the reading.

5. If there is any gap or light between the blade of the square and the Scale Miter Gauge fence or saw blade, one or a combination of the following could be the cause:
 - a. The saw blade is not parallel to the miter slot of the saw. To resolve this, adjust the saw trunnion or table as needed per the instructions provided by the manufacturer of your tool to bring the blade into parallelism with the miter gauge slot.
 - b. The Scale Miter Gauge head is not perpendicular with its miter bar. To resolve this, refer to see page 16

ZERO THE FENCE RULER

The rulers attached to the fence can be used in conjunction with the adjustable dual flip stop for convenient repeatable cuts. The calibration steps are different for the ruler on the main fence extrusion vs. the lower ruler located on the fence extension. For maximum utility of your Scale Miter Gauge, follow the steps for calibrating both rulers.

The illustrations below assume the Scale Miter Gauge is currently configured for use in the table saw miter slot to the left of the blade and that the rulers that came pre-installed on your Scale Miter Gauge are installed. If you perform these calibration steps and later choose to reverse the setup of your Scale Miter Gauge for use in the right side miter slot (see **Reversing the Fence Extension** on page 12), these calibration procedures will then need to be repeated.

Main Fence Ruler Calibration

Follow these steps to adjust the position of the flip stops on the carrier to ensure the accuracy of the ruler on the main fence extrusion.

1. Confirm that the ruler attached to the fence has the zero mark adjusted to the edge of the fence

extrusion that is closest to the blade. Adjust the position of the ruler if necessary.

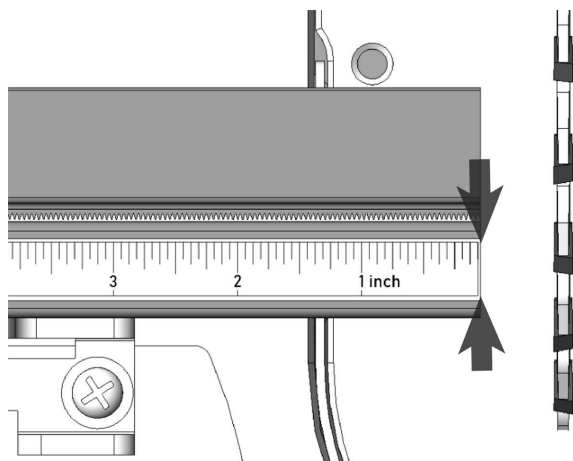

2. Loosen the nylon thumb screws on the back of the flip stop carrier and position the edge of the carrier to be also at the zero mark of the fence ruler.

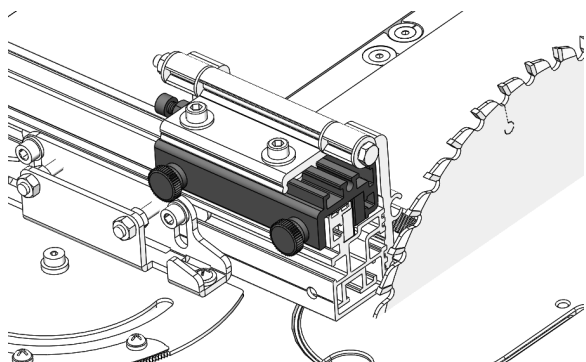

3. Set the gap (A) between the edge of the fence (B) and the saw blade (C) approximately 3/8" (9.5mm) from the blade. (See **Setting Safe Fence Distance from Blade** on page 11 for instructions.)

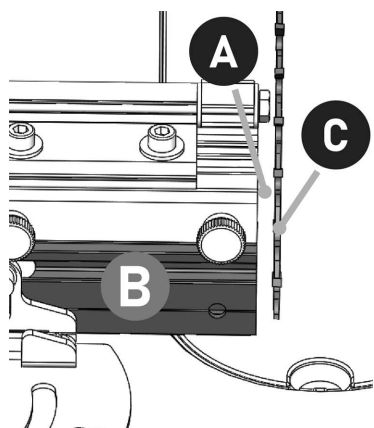

4. Loosen the socket head bolts indicated in the illustration below so that the flip arm assembly is freely moveable. Slide the flip arm so that the edge of the stop barely brushes the sides of the saw blade teeth. Take care to not deflect the blade.

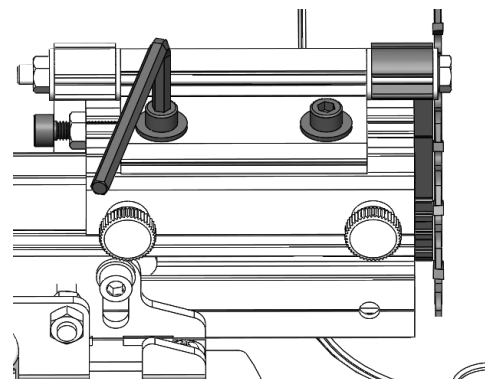

! IMPORTANT:

Key to this calibration process is that the flip stop registers against the edge of the teeth of the blade (as described in step 4) and not against the flat of the steel surface of the blade. The teeth are typically wider than the steel of the blade making this detail important to achieving precision.

5. It is helpful to employ the fine adjustment feature of the flip stop to positioning the stop. (See **Position the Dual Flip Stop - Fine Adjustments** on page 13 for instructions.) Again, the goal is to have the leading edge of the flip arm barely contacting the teeth of the blade. With your saw powered off and unplugged, MANUALLY rotate the blade a few times to confirm the teeth do not catch on the edge of the flip stop. The steel of the blade may however faintly "ring" as the teeth pass by the flip stop.
6. Re-tighten the socket head bolts you loosened in step 4.

This calibration step is now complete and the built-in ruler can be relied upon for accurate length of cut. You will read the ruler at the edge of the moveable flip stop carrier. Tighten the nylon thumb screws once the flip stop carrier is positioned. Do not over-tighten.

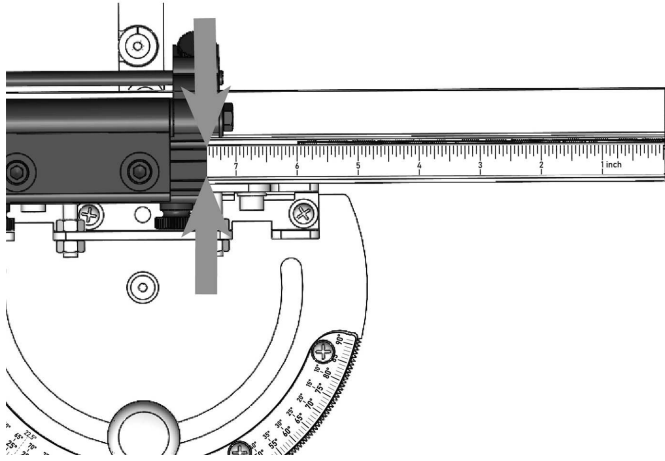

See the chapter, **USING THE DUAL FLIP STOP SYSTEM** on page 13 for further instructions.

Fence Extension Ruler Calibration

Follow these steps to calibrate the lower ruler that is exposed when the fence extension is used. An accurate measuring tape will be needed to complete this calibration.

1. Using a 5mm hex wrench, loosen the socket head fence extension bolt shown, and extend the fence a few inches as shown.

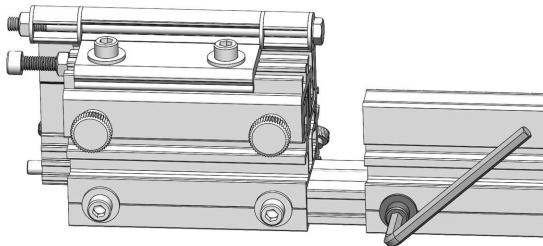

2. Loosen both nylon thumbscrews on the back of dual flip stop assembly at least one full revolution. Push the flip stop carriage forward slightly before moving it from its current location along the top of the fence.

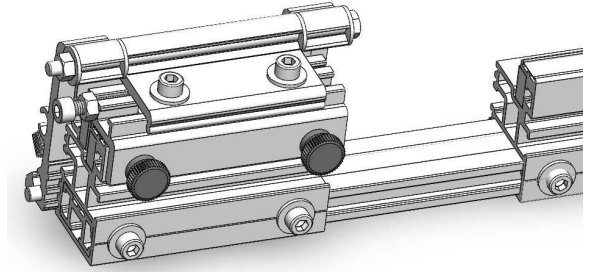

3. Position the edge of flip stop carriage that is closest to the blade to be perfectly flush with the edge of the tall extrusion attached to the end of the extension as shown.

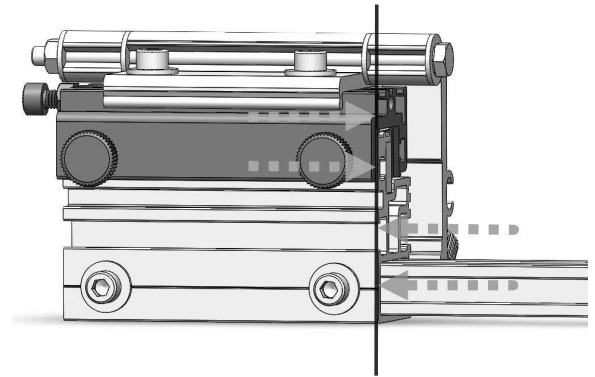

Next, secure the flip stop carrier with the thumbscrews you loosened in the previous step. Do not over tighten.

4. Pull the telescoping extension further and confirm that the correct ruler is installed in the extension. The lowest numbers on this ruler should be positioned furthest from the blade. If this is not so, a reverse ruler was included with your Scale Miter Gauge that should be installed at this time. To remove the current ruler, slide it down the length of the slot in which it is fitted and install the alternate ruler in its place by feeding it into the end of the extruded slot.

- Extend the telescoping extension until the flip stop closest to the blade is positioned at a known distance from the blade. In this example, we'll measure 20" using a measuring tape laid out in front of the miter gauge. For best accuracy, be sure to measure from the side of the blade teeth as opposed to measuring from the flat of the blade.

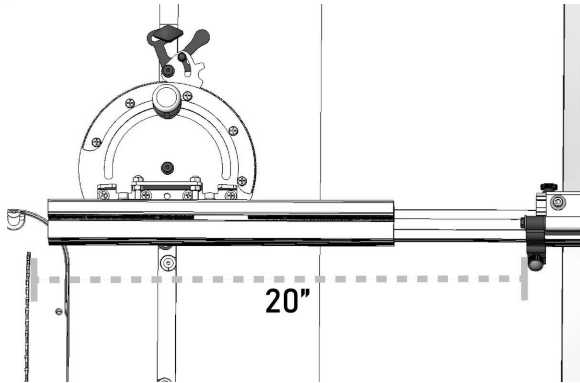

- Re-secure the fence extension retention bolt you loosened in step 1 to fix the extension at this 20" position. Confirm the measurement with your measuring tape after tightening the bolt and adjust if necessary.
- Read the lower fence ruler where the extension bar meets the extrusion of the main fence. If it does not read precisely 20", adjust the position of measuring tape in the extension bar until a reading of precisely 20" is achieved.

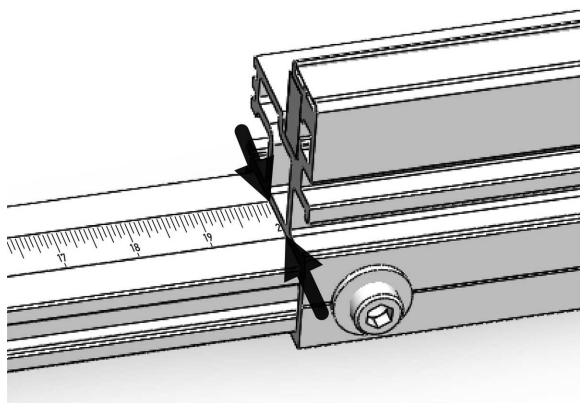

The measuring tape is held into the extension extrusion by friction and is not glued. By design, it does not move freely, but with some effort, it can be adjusted as described.

The fence extension ruler is now calibrated.

NOTE:

If you have need to redo the main fence ruler calibration or change the precision adjustment on the flip stop, the extension ruler calibration steps will need to be repeated.

How to Read the Rulers

When setting the flip stop for measurements up to 14 1/4" (362mm), you'll read the top ruler on the main fence extrusion at the edge of flip stop carrier closest to the blade.

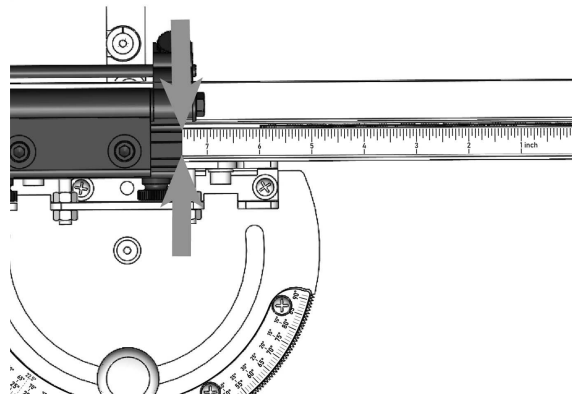

When using the flip stop in conjunction with the fence extension (measurements over 14 1/4" (362mm)), read the measurement from the lower ruler where the extension bar meets the extrusion of the main fence as shown in step 7.

IMPORTANT:

To ensure measurement accuracy when utilizing the flip stop in conjunction with the telescoping fence extension, always begin by positioning flip stop carriage as described above in step 3.

TROUBLESHOOTING

PROBLEM	POSSIBLE CAUSE(S)	SOLUTION
Inaccurate angle cuts.	The angle cuts may not be precise due to the miter gauge being improperly aligned with the saw blade.	Refer to CALIBRATION on page 16 of this manual for detailed procedures to ensure blade alignment to the miter gauge and miter slot is correct.
Loose fit of miter bar in table slot.	The miter gauge may be loose and move around during use, causing inaccurate cuts.	See the chapter called ADJUST THE MITER BAR FIT on page 5 of this manual for detailed procedures to remedy this.
Workpiece is slipping.	The workpiece may slip out of place while cutting, causing inaccurate cuts.	Check the <i>Grip</i> on the miter gauge and confirm that it is sufficiently tightened before beginning cutting operations. Also, ensure you are taking care to firmly hold your workpiece against the miter gauge fence during cutting operations.
Miter gauge is binding while moving material across the table.	The miter gauge may bind or become stuck during use preventing accurate cuts.	Check for any debris or sawdust that may be interfering with the movement of the miter gauge. Clean the miter gauge, saw table surface and the miter slots thoroughly before use. In rare cases, there may be minor imperfections in the milling of the miter slot on your tool. Careful and judicious use of a fine metal file to reduce high spots on the sidewall of the miter slot may be required to remedy this issue.
Fence face is not perpendicular to the saw table.	The bracket to which the fence is attached needs minor adjustments.	The Scale Miter Gauge fence is factory-adjusted to be square to the saw table, minimizing the need for additional adjustments. Should you desire to make changes, a detailed service bulletin is available for download at SawStop.eu/support or SawStop.uk/support .





SawStop.eu

SawStop.uk

SalesEurope@SawStop.com

SupportEurope@SawStop.com

SawStop 11555 SW Myslony St, Tualatin, OR 97062 USA

TTS Europe SE 73240 Wendlingen a.N., DE

UK Rep Authorised Rep Compliance Ltd., ARC House,
Thurnham, Lancaster, LA2 0DT, UK.