

Woodpeckers®

STEADYCURVE BAND SAW TEMPLATE GUIDE

OWNER'S MANUAL

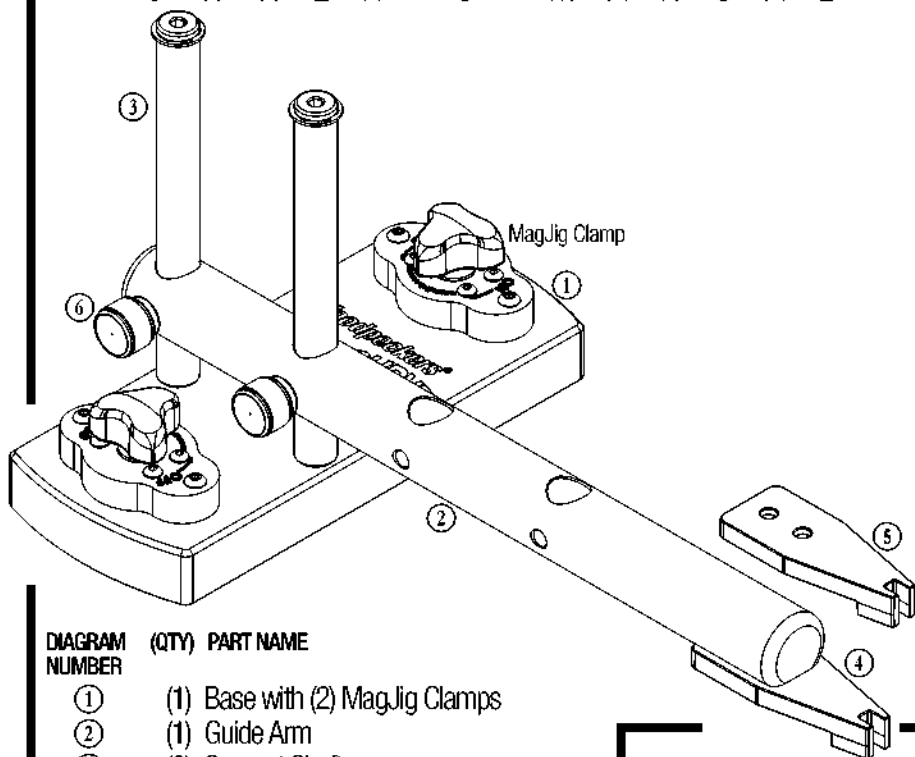

DIAGRAM (QTY) PART NAME NUMBER

- ① (1) Base with (2) MagJig Clamps
- ② (1) Guide Arm
- ③ (2) Support Shaft
- ④ (1) 1/4" Guide*
- ⑤ (1) 1/8" Guide*

HARDWARE BAG

- ⑥ (2) Height Adjustment Knob
- (2) Socket Head Screw, 1/4-20 x 3/4
- (2) Button Head Screw, #10-32 x 3/8
- (1) Hex Key 1/8"
- (1) Hex Key 5/32"
- (1) Hex Key 3/16"

*Replacements also sold as 2-Packs on woodpeck.com.



Scan the QR code above
to watch the video
or visit woodpeck.com
under the video tab towards
the bottom of the product page.

If you think you're missing anything, email us at mailroom@woodpeck.com.
You can also call us at 800-752-0725 from 9:00 a.m. to 4:00 p.m. EST, Monday - Friday.

DETERMINE YOUR CONFIGURATION: Use the **I. Long Arm Configuration** instructions if you have sufficient table surface.

If you have a small table, then assemble your SteadyCurve in the **II. Short Arm Configuration**.

I. LONG ARM CONFIGURATION

1. Place the (2) Height Adjustment Knobs (6) into the back two threaded holes of the Guide Arm (2). *Get them started but do not thread them all the way in.*

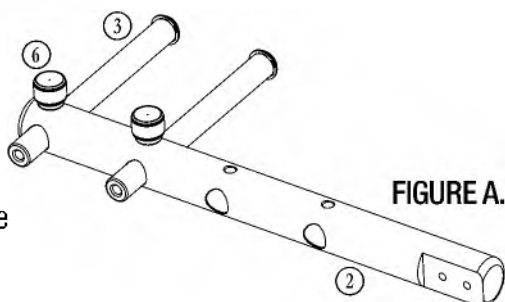
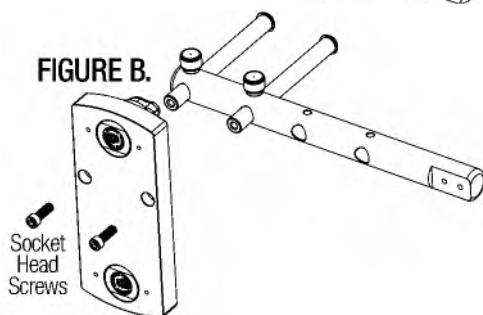

FIGURE A.

2. Install the (2) Support Shafts (3) into the two back (1/2") holes on the Guide Arm.

NOTE: The threaded ends of the Support Shafts should be facing the same way as the flat on the end of the Guide Arm. **FIGURE A.**

3. Place the (2) Support Shafts over the (2) holes in the Base (1) and start the (2) Socket Head Screws. **NOTE:** Height Adjustment Knobs face away from logo. **FIGURE B.**



→ Continue to Step 4, Page 3...

II. SHORT ARM CONFIGURATION

1. Place the (2) Height Adjustment Knobs (6) into the front two threaded holes of the Guide Arm (2). *Get them started but do not thread them all the way in.*

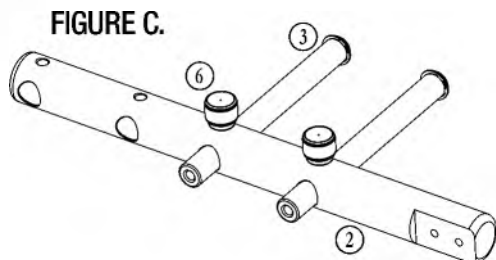
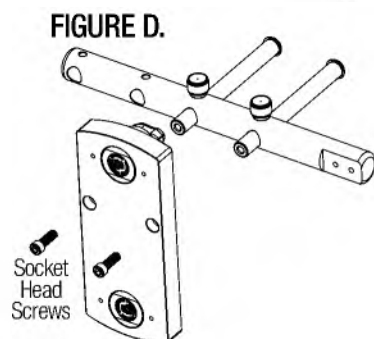

FIGURE C.

2. Install the (2) Support Shafts (3) into the two front (1/2") holes on the Guide Arm. **NOTE:** The threaded ends of the Support Shafts should be facing the same way as the flat on the end of the Guide Arm. **FIGURE C.**

3. Place the (2) Support Shafts over the (2) holes in the Base (1) and start the (2) Socket Head Screws. **NOTE:** Height Adjustment Knobs face away from logo. **FIGURE D.**



→ Continue to Step 4, Page 3...

4. With the (2) Socket Head Screws still loose, bring the Guide Arm all the way down to the Base and tighten the (2) Height Adjustment Knobs.

5. Use a 3/16" Hex Key and a 5/32" Hex Key to tighten the (2) Socket Head Screws into the Support Shafts.

6. Loosen the (2) Height Adjustment Knobs and ensure that the Guide Arm moves freely up and down.

7. Using a 1/8" Hex Key, install the Guide (your choice (4) or (5)) with the lip of the Guide facing downward, onto the flat end of the Guide Arm with the (2) Button Head Screws. **FIGURE E.**

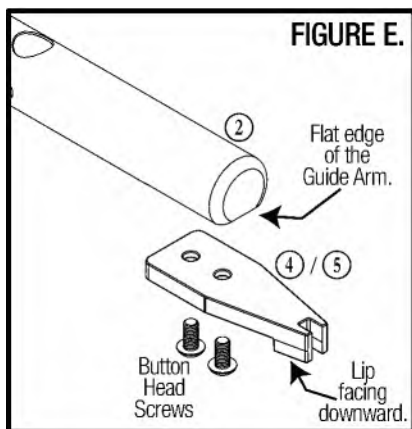

III. SETTING UP THE STEADYCURVE

NOTE: Before you begin, ensure that your band saw is setup correctly and the blade is under proper tension.

1. POSITION THE BASE

a. Loosen the (2) Height Adjustment Knobs (6) and move the Guide Arm (2) down to the Base (1).

b. With the MagJigs turned "OFF", position the SteadyCurve so that the band saw blade is centered in the opening of the Guide and inset about 1/8" (*this inset amount is what determines the stock left on your workpiece after band saw template cutting*). **FIGURE F.**

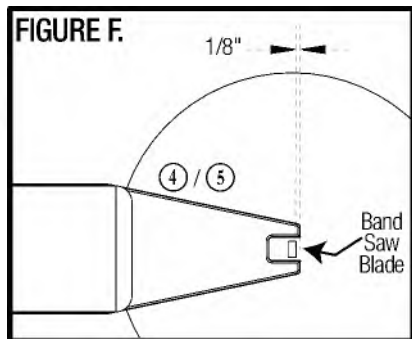

c. Hold the Base in position and turn the MagJigs "ON". Make sure the Base is tightly adhered to your band saw table.

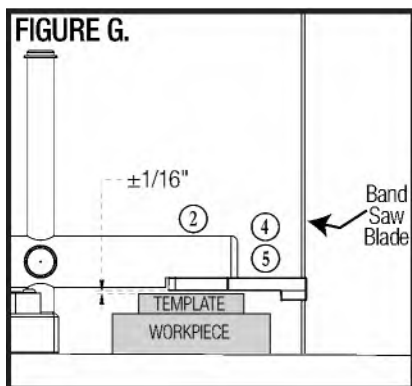

2. SET THE HEIGHT

a. Use your template (secured to your workpiece) to set the height of the Guide. Lower the Guide Arm (2) as low as possible while maintaining clearance between the bottom of the Guide Arm and the top of the template. Tighten the (2) Height Adjustment Knobs to lock the Guide Arm into place. **FIGURE G.**

IV. USING THE STEADYCURVE

- Attach a template that is at least 1/4" thick, (3/8" to 3/4" is preferred) to your workpiece with your preferred method (for example double-sided tape, spray adhesive, brads, etc.).
- Evaluate your pattern and make clearance cuts where necessary. Cut off any large waste areas.
- For best results, keep both front and back sides of the SteadyCurve Guide in contact with the template side as you make your cuts.
- Once you complete the rough cut at the band saw, you should have a slightly oversized workpiece with a consistent amount of stock remaining on all sides.
- Before removing the template, take your workpiece to your router equipped with a flush trim bit and finish the profile. The small amount of stock remaining when flush trimming will ensure a consistent smooth finish, as well as help prevent grabbing and tearing the end grain areas on your workpiece.
- You can adjust the amount of stock left around the template by moving the Magnetic Base of the SteadyCurve on your table. (See III. Setting Up the SteadyCurve on page 3.)



WARNING! To reduce the risk of injury keep hands away from moving parts. Refer to your power tool manual for proper setup and use.



WARNING! To reduce the risk of injury, wear safety goggles or glasses with side shields, ear protection & a dust mask.

Woodpeckers®

Woodpeckers, LLC Strongsville, Ohio
woodpeck.com
© 2023 Woodpeckers, LLC



At Woodpeckers we are constantly reviewing & improving our tools. The most current version of our instruction manuals are always available to download at woodpeck.com.

(Located in the bottom section of the tool's page under the "Additional Information" or "Instructions" tabs.)



Be the first to know all the new products, OneTIME Tools & sales by subscribing to our eClub. *(Located at the top center of our webpage woodpeck.com.)*



Subscribe to our YouTube channel to stay up-to-date on all the latest tool tips & tricks.



INTERACT WITH US! Follow us on Facebook, Instagram & TikTok!



Enjoy shop tips, project ideas, tool techniques & more in our Woodworking Resource Center/Blog. *(Located at the bottom center of our webpage woodpeck.com.)*



WARNING! This product can expose you to chemicals, including chromium, which is known to the State of California to cause cancer and birth defects or other reproductive harm. For more information go to www.P65Warnings.ca.gov