

Woodpeckers®

CLAMPZILLA™

4-WAY PANEL CLAMP

OWNER'S MANUAL

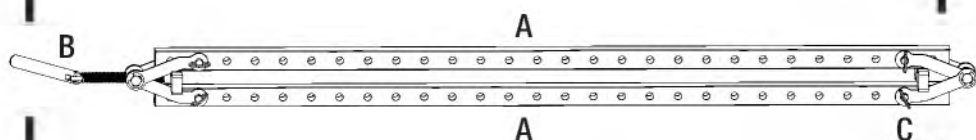
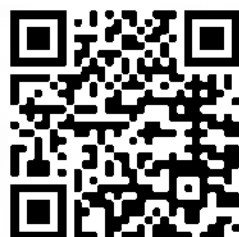

DIAGRAM LETTER	(QTY)	PART NAME
A	(2)	Clamping Bars <i>ClampZilla 50" / 38" / 18" Capacity</i>
B	(1)	Threaded Clamping End (1) Handle (with Screw) (1) Clamping Pad (1 Set) Centering Devices
C	(1)	Stationary Clamping End (1) Clamping Pad (1 Set) Centering Devices (4) Quick Release Pins

Sold Separately (2) ClampZilla 50" Capacity Extended Bars

Sold Separately (2) ClampZilla 18" Capacity Extended Bars



Scan the QR code above
to watch the video
or visit woodpeck.com
under the video tab towards
the bottom of the product page.

Woodpeckers® ClampZILLA™ 4-Way Panel Clamp places a bar on both sides of your stock with centering devices that direct the pressure to the exact center of your stock. Not only does ClampZILLA focus the lateral pressure on the center of your panel, it also puts vertical pressure on the boards, helping to hold them in alignment to each other.

If you think you're missing anything, email us at mailroom@woodpeck.com.
You can also call us at 800-752-0725 from 9:00 a.m. to 4:00 p.m. EST Monday - Friday.

LOADING THE CLAMPZILLA

1. Remove the top Quick-Release Pin from the Stationary Clamping End of the Clamp.
2. Pivot the top Clamping Bar out of the way. **FIGURE A**
3. Remove the other Quick Release Pin on the Stationary Clamping End.
4. Move the Stationary Clamping End to the set of holes on the Clamping Bars closest to the width of your material.
5. Install the lower Quick Release Pin.
6. Spread glue on your boards and align them on the lower Clamping Bar.
7. Pivot the top Clamping Bar into place and install the upper Quick Release Pin into the Stationary Clamping End.
8. Tighten the Clamp by turning the Handle on the Threaded Clamping End. **FIGURE B**

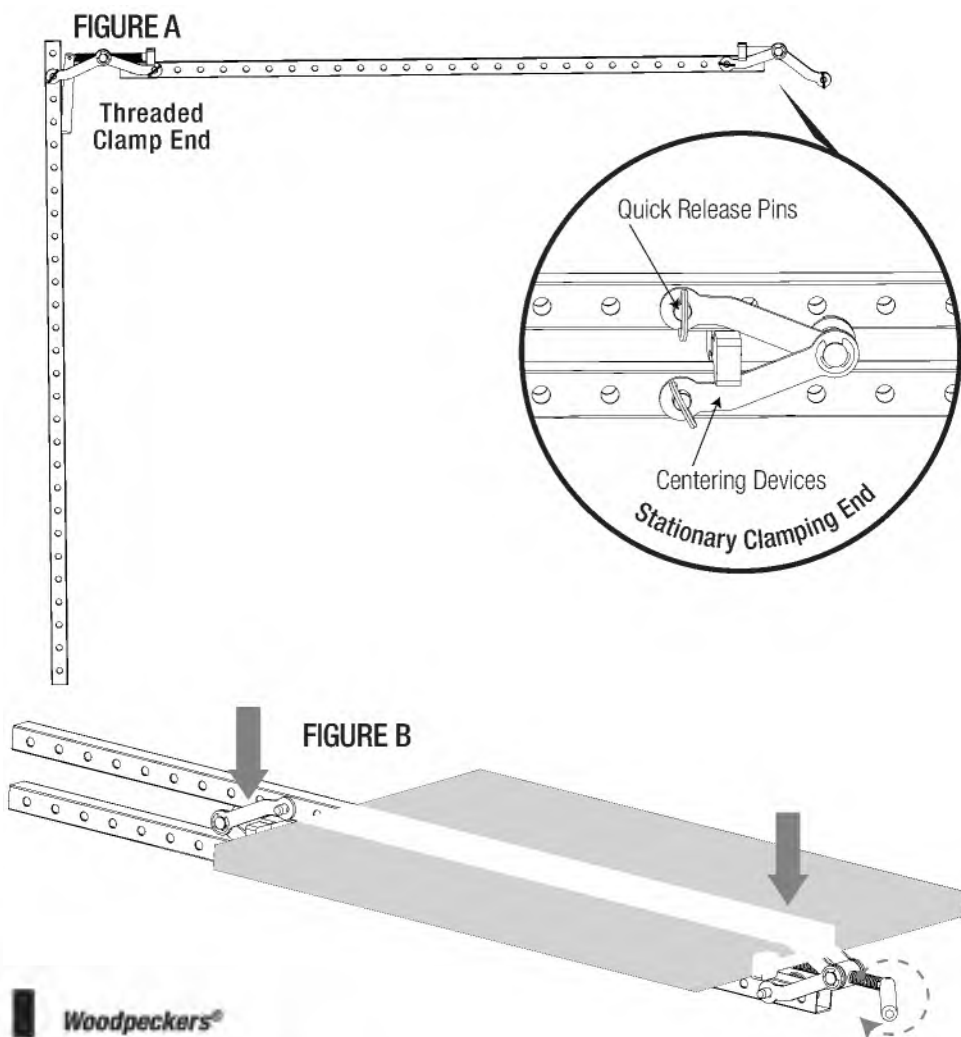

CLAMPING THINNER STOCK

The Clamping Bars will come against the Clamping Pads before engaging stock thinner than 5/8". You can overcome this by placing scrap stock in line with the clamping bars, above and below your glue-up. **FIGURES D & E**

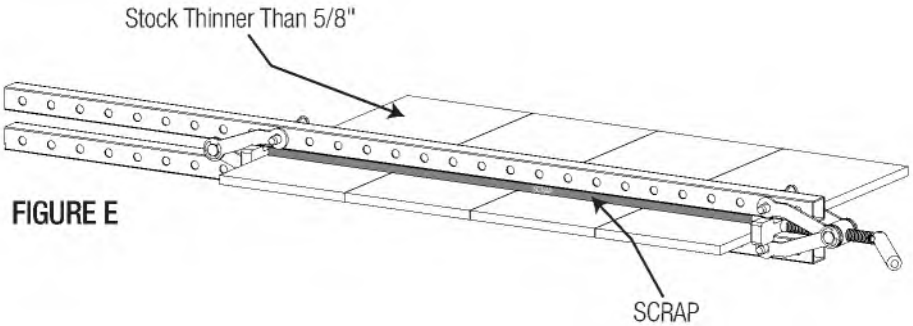
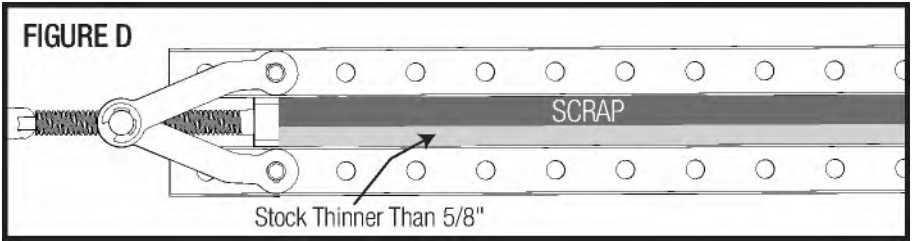
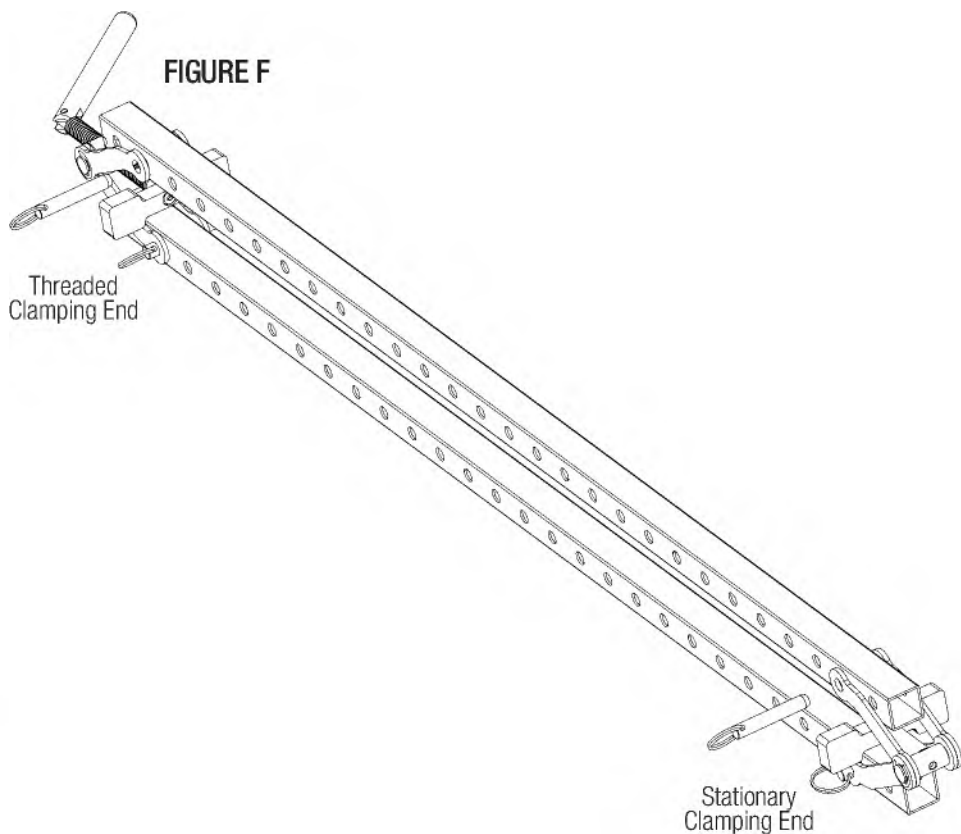

FIGURE E

INSTALLING EXTENDED CAPACITY BARS *(Sold Separately)*

1. Remove the Quick Release Pins from the ClampZilla. **FIGURE F-2**
2. Replace the standard capacity Clamping Bars with the Extended Capacity Bars.
5. Replace the Quick Release Pins in the Stationary Clamping End.
6. Replace the Quick Release Pins on the Threaded Clamping End.



Woodpeckers[®]

Woodpeckers, LLC Strongsville, Ohio

woodpeck.com

© 2023 Woodpeckers, LLC



woodpeck.com

At Woodpeckers we are constantly reviewing & improving our tools. The most current version of our instruction manuals are always available to download at woodpeck.com.

(Located in the bottom section of the tool's page under the "Additional Information" or "Instructions" tabs.)



Be the first to know all the new products, *OneTIME* Tools & sales by subscribing to our eClub. *(Located at the top center of our webpage woodpeck.com.)*



Subscribe to our YouTube channel to stay up-to-date on all the latest tool tips & tricks.



INTERACT WITH US! Follow us on Facebook, Instagram & TikTok!



Enjoy shop tips, project ideas, tool techniques & more in our Woodworking Resource Center/Blog. *(Located at the bottom center of our webpage woodpeck.com.)*

REV071322



WARNING! This product can expose you to chemicals, including chromium, which is known to the State of California to cause cancer and birth defects or other reproductive harm. For more information go to www.P65Warnings.ca.gov